

**VERSA 2000 (RT1)**

**SERVICE AND REFERENCE MANUAL**



## **PROPRIETARY NOTICE AND LIABILITY DISCLAIMER**

The information disclosed in this document, including all designs and related materials, is the valuable property of NEC Corporation (NEC) and/or its licensors. NEC and/or its licensors, as appropriate, reserve all patent, copyright and other proprietary rights to this document, including all design, manufacturing, reproduction, use, and sales rights thereto, except to the extent said rights are expressly granted to others.

The NEC product(s) discussed in this document are warranted in accordance with the terms of the Warranty Statement accompanying each product. However, actual performance of each such product is dependent upon factors such as system configuration, customer data, and operator control. Since implementation by customers of each product may vary, the suitability of specific product configurations and applications must be determined by the customer and is not warranted by NEC.

To allow for design and specification improvements, the information in this document is subject to change at any time, without notice. Reproduction of this document or portions thereof without prior written approval of NEC is prohibited.

FastFacts, and NEC SVGA, are U.S. trademarks of NEC Technologies, Inc.

All other product, brand, or trade names used in this publication are the trademarks or registered trademarks of their respective trademark owners.

---

Preface .....	vii
Abbreviations .....	ix

## Section 1 Technical Information

Hardware Overview.....	1-2
Liquid Crystal Display (LCD).....	1-3
System Board .....	1-3
Battery Pack .....	1-4
CMOS Battery.....	1-4
Bridge Battery .....	1-4
PCMCIA Slots.....	1-4
Keyboard .....	1-4
NEC VersaGlide.....	1-5
System Memory.....	1-5
Memory Map.....	1-6
System Video.....	1-7
Parallel Interface.....	1-11
Serial Interface.....	1-11
NEC Versa 2000 Series Chip Set.....	1-11
System Logic.....	1-12
Flash ROM .....	1-12
ROM BIOS.....	1-12
Peripheral Controller .....	1-13
VGA Controller.....	1-13
Video Controller Architecture.....	1-13
Diskette Controller, Serial Interface, Parallel Interface .....	1-14
Keyboard Controller.....	1-14
PCMCIA Controller .....	1-14
I/O Addressing .....	1-15
Interrupt Controllers.....	1-16
Power Management Overview .....	1-17
System Power Management.....	1-17
Local Power Management.....	1-17
Plug and Play.....	1-18
Specifications .....	1-19

## Section 2 Setup and Operation

---

Unpacking the System .....	2-1
Setup .....	2-1
Cable Connections.....	2-2
Operating Controls .....	2-3
LEDs.....	2-4
Function Keys (Fn Keys).....	2-5
CMOS Clear Switch and Keyboard Switch .....	2-6
Smart Power Switch .....	2-7
Power-on Self-Test (Post) .....	2-7
POST Errors .....	2-8
System Parameters.....	2-9
Auto Setup.....	2-9
Accessing Auto Setup .....	2-9
Auto Setup Keys .....	2-10
Auto Setup Parameter Options .....	2-11
Parameter Descriptions .....	2-12
Comms .....	2-12
Drives .....	2-12
Keyboard.....	2-12
Power .....	2-13
System.....	2-13
Time/Date.....	2-14
Using Auto Setup to Select Parameters.....	2-14
Security Options .....	2-15
System Password.....	2-15
Using the System Password .....	2-15
Keyboard Lock Hotkey .....	2-16
NEC Utilities .....	2-17
BIOS Update Utility (BUU).....	2-17
Precautions .....	2-17
Downloading the Update Utility .....	2-18
Using the Update Utility .....	2-18
Menu Functions.....	2-20
Power Sources .....	2-24
AC Adapter .....	2-24
Battery Power .....	2-25
Recharging the Battery Pack .....	2-26

---

Replacing the Battery Pack.....	2-26
Saving Battery Power .....	2-27
Automatic Power-Saving Features .....	2-28
Power Saving Levels.....	2-28
Active Mode.....	2-28
Suspend Mode.....	2-28

### Section 3 Illustrated Parts Breakdown

### Appendix A Connector Locations and Pin Assignments

#### List of Figures

1-1	Versa 2000 Series (Right Side View) .....	1-1
1-2	Versa 2000 Series (Left Side View).....	1-2
1-3	Versa 2000 Series (Rear View).....	1-3
2-1	Power and I/O Connector Locations .....	2-2
2-2	Control and Switch Locations.....	2-3
2-3	CMOS Clear and Keyboard Switch Locations .....	2-6
2-4	Connecting the AC Adapter .....	2-25
2-5	Battery Release Latch Location.....	2-26
2-6	Battery Pack Replacement .....	2-27
3-1	Illustrated Parts Breakdown .....	3-4
A-1	System Board Connector Locations.....	A-1

#### List of Tables

1-1	Versa 2000 Series Memory Map.....	1-6
1-2	CRT Display Mode (CRT only).....	1-7
1-3	LCD Display Modes (640 x 480 TFT, Simultaneous CRT) .....	1-9
1-4	LCD Display Modes (640 x 480 DSTN, Simultaneous CRT).....	1-10
1-5	Versa 2000 Series Chip Types and Technologies.....	1-11
1-6	Versa 2000 Series I/O Address Map.....	1-15
1-7	Versa 2000 Series Interrupt Level Assignments .....	1-16
1-8	Specifications .....	1-19

---

2-1	I/O Connector Descriptions.....	2-2
2-2	Control and Switch Functions.....	2-4
2-3	FnKey Operations .....	2-5
2-4	POST Error Messages.....	2-8
2-5	Auto Setup Key Functions .....	2-10
2-6	Auto Setup Parameter Options.....	2-11
2-7	Automatic Power-Saving Features.....	2-28
3-1	Versa 2000 Series Field-Replaceable Parts.....	3-1
3-2	Option and Documentation Part Numbers .....	3-5
A-1	System Board Connectors .....	A-1
A-2	Keyboard/Mouse Connector Pin Assignments .....	A-2
A-3	Serial Port Connector Pin Assignments .....	A-3
A-4	CRT Connector Pin Assignments .....	A-3
A-5	Parallel Printer Pin Assignments.....	A-4
A-6	Docking Connector Pin Assignments .....	A-5
A-7	Power Connector.....	A-9
A-8	Hard Disk Drive Connector .....	A-10

---

## **Preface**

This service and reference manual contains the technical information necessary to set up, and maintain the NEC Versa™ 2000 Series Notebook systems. It also provides hardware and interface information for users who need an overview of the computer system design. The manual is written for NEC-trained customer engineers, system analysts, service center personnel, and dealers.

Please refer to the training module provided on CD-ROM for disassembly/assembly procedures.

The manual is organized as follows:

**Section 1 — Technical Information**, provides an overview of the hardware and interface components. System specifications are listed including computer dimensions, weight, environment, safety compliance, power consumption, and system memory specifications.

**Section 2 — Setup and Operation**, takes the user from unpacking to setup and operation. The section includes a description of operating controls, setting parameters and accessing the NEC bulletin board system (BBS).

**Section 3 — Illustrated Parts Breakdown (IPB)**, provides an exploded-view diagram of the Versa 2000 series system and part numbers.

**Appendix A — Connector Locations and Pin Assignments**, provides a list of the main board internal connector pin assignments and a list of external pin assignments.

An **Index** is included for convenience.

---

## **Abbreviations**

A	ampere
AC	alternating current
AT	advanced technology (IBM PC)
BBS	Bulletin Board System
BCD	binary-coded decimal
BCU	BIOS Customized Utility
BIOS	basic input/output system
bit	binary digit
bpi	bits per inch
bps	bits per second
BUU	BIOS Upgrade Utility
C	centigrade
Cache	high-speed buffer storage
CAM	constantly addressable memory
CAS	column address strobe
CD-ROM	compact disk-ROM
CGA	Color Graphics Adapter
CGB	Color Graphics Board
CH	channel
clk	clock
cm	centimeter
CMOS	complementary metal oxide semiconductor
COM	communication
CONT	contrast
CPGA	ceramic pin grid array
CPU	central processing unit
CRT	cathode-ray tube
DAC	digital-to-analog converter
DACK	DMA acknowledge
DC	direct current
DIP	dual in-line package
DLAB	Divisor Latch Address bit
DMA	direct memory access
DMAC	DMA controller
DOS	disk operating system

---



DRAM	dynamic RAM	
DTE	data terminal equipment	
ECC	error checking and correction	
EDS	error detecting system	
EGA	Enhanced Graphics Adapter	
EMS	Expanded Memory Specification	
EPP	enhanced parallel port	
EPROM	erasable and programmable	ROM
EVGA	Enhanced Video Graphics	Array
F	Fahrenheit	
FAX	facsimile transmission	
FCC	Federal Communications	Commission
FG	frame ground	
FM	frequency modulation	
Fn	Function	
FRU	field-replaceable unit	
GB	gigabyte	
GND	ground	
HDD	hard diskdrive	
HEX	hexadecimal	
HGA	Hercules Graphics Adapter	
Hz	hertz	
IC	integrated circuit	
ID	identification	
IDE	intelligent device electronics	
IDTR	interrupt descriptor table register	
IMR	Interrupt Mask register	
in.	inch	
INTA	interrupt acknowledge	
IPB	illustrated parts breakdown	
IRR	Interrupt Request register	
ISA	Industry Standard Architecture	
ISR	In Service register	
I/O	input/output	
IPC	integrated peripheral controller	
ips	inches per second	
IRQ	interrupt request	

---

K	kilo (1024)	
k	kilo (1000)	
KB	kilobyte	
kg	kilogram	
kHz	kilohertz	
kV	kilovolt	
lb	pound	
LDTR	local descriptor table register	
LED	light-emitting diode	
LSB	least-significant bit	
LSI	large-scale integration	
M	mega	
mA	milliamps	
max	maximum	
MB	megabyte	
MDA	Monochrome Display Adapter	
MFM	modified frequency modulation	
Mhz	megahertz	
mm	millimeter	
ms	millisecond	
MSB	most-significant bit	
NASC	National Authorized Service	Center
NC	not connected	
NDP	numeric data processor	
NMI	Non-maskable Interrupt	
ns	nanosecond	
NSRC	National Service Response	Center
PAL	programmable array logic	
PC	personal computer	
PCB	printed circuit board	
PFP	plastic flat package	
PIO	parallel input/output	
pixel	picture element	
PJQFP	plastic J-lead quad flat pack	
PLCC	plastic lead chip carrier	
PLL	phase lock loop	
p-p	peak-to-peak	

---

PPI	programmable peripheral	interface
PROM	programmable ROM	
QFP	quad flat pack	
RAM	random-access memory	
RAMDAC	RAM digital-to-analog	
RAS	row address strobe	
RGB	red green blue	
RGBI	red green blue intensity	
ROM	read-only memory	
rpm	revolutions per minute	
R	read	
RTC	real-time clock	
R/W	read/write	
S	slave	
SCSI	Small Computer System Interface	
SDLC	Synchronous Data Link Control	
SG	signal ground	
SIMM	single inline memory module	
SQFP	silver quad flat package	
SVGA	Super Video Graphics Array	
SW	switch	
TAC	Technical Assistance Center	
TCP	Thin chip package	
TQFP	Thin-quad flat package	
TSC	Technical Support Center	
TTL	transistor/transistor logic	
tpi	tracks per inch	
UART	universal asynchronous receiver/transmitter	
V	volt	
Vdc	volts, direct current	
VESA	video electronics standards	association
VFO	variable frequency oscillator	
VGA	Video Graphics Array	
VLSI	very large-scale integration	
VRAM	virtual RAM	
W	watt	
W	write	

---

$\mu\text{f}$	microfarad
$\mu\text{PD}$	microprocessor
$\mu\text{s}$	microsecond
$\Omega$	ohm



## Section 1

### Technical Information

The NEC Versa 2000 series computers integrate the Intel<sup>®</sup> 486 DX4-75 chip. The systems offer a unique transportable unit in the following configurations:

- NEC Versa 2000C — 75-MHz CPU, 350-MB hard disk drive, 9.5-inch thin-film transistor (TFT) color LCD, 4-MB standard RAM, 1-MB video memory, 256-KB ROM, no modem
- NEC Versa 2000C — 75-MHz CPU, 350-MB hard disk drive, 9.5-inch thin-film transistor (TFT) color LCD, 8-MB standard RAM, 1-MB video memory, 256-KB ROM, 14.4K bps data fax/modem
- NEC Versa 2000C — 75-MHz CPU, 540-MB hard disk drive, 9.5-inch thin-film transistor (TFT) color LCD, 8-MB standard RAM, 1-MB video memory, 256-KB ROM, 14.4K bps fax/modem
- NEC Versa 2000D — 75-MHz CPU, 350-MB hard disk drive, 10.4-inch Dual-scan Super Twisted Nematic (DSTN) color LCD, 4-MB standard RAM, 1-MB video memory, 256-KB ROM, no modem

Figure Section 2-1 and Figure Section 2-2 show system features.

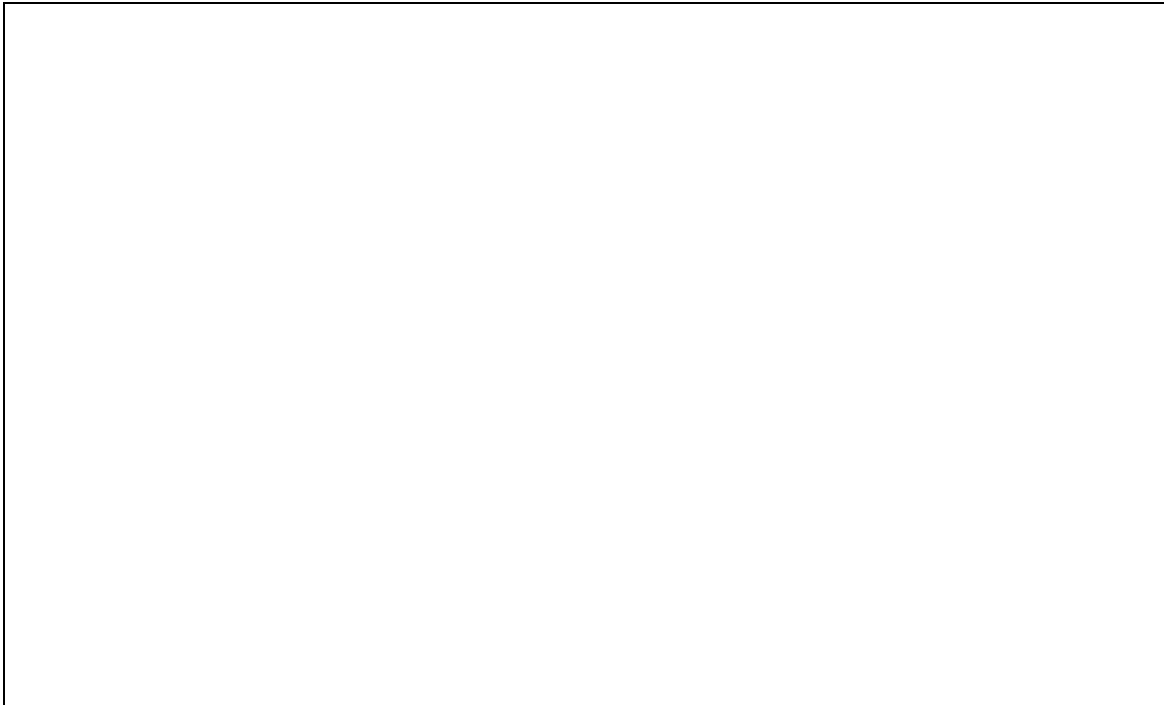

***Figure Section 2-1 Versa 2000 Series (Right Side View)***

---

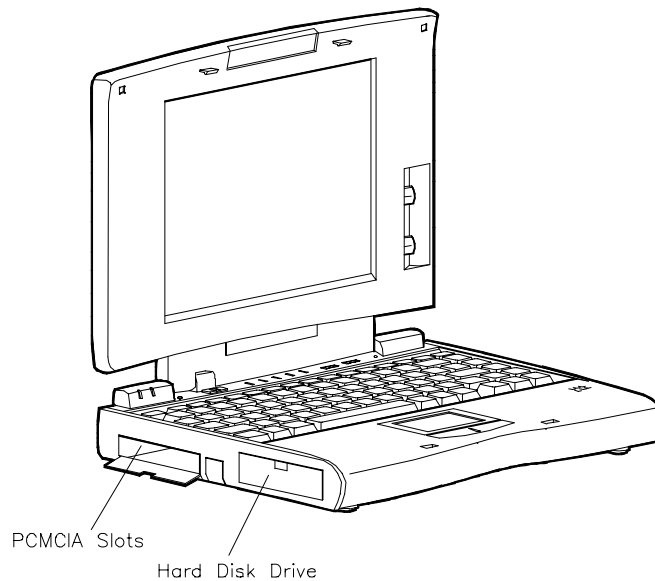

**Figure Section 2-2 Versa 2000 Series (Left Side View)**

## **HARDWARE OVERVIEW**

The base unit includes a color LCD panel, a 2 1/2-inch 350-MB, or 540-MB hard disk drive, a 3 1/2-inch, 1.44-MB diskette drive, a battery pack, and a PS/2 compatible 83-key keyboard. A 79-key keyboard is used for U.K. and Germany.

Two memory cards slot are available for the addition of a 4-, 8- or 16-MB capacity memory card. Two Personal Computer Memory Card International Association (PCMCIA) card slots, supported by the Cirrus Logic CL-PD6720 PCMCIA controller, allow for the addition of either two PCMCIA Type I/Type II cards or one PCMCIA Type III card.

Figure Section 2-3 shows the standard I/O interface ports on the system's rear panel. These include one 6-pin shared PS/2-style keyboard/mouse port, one 9-pin (RS-232C) serial port, one 25-pin enhanced printer (parallel) port, one docking connector, one 15-pin Super VGA CRT port, and one 3-pin power connector port.

---

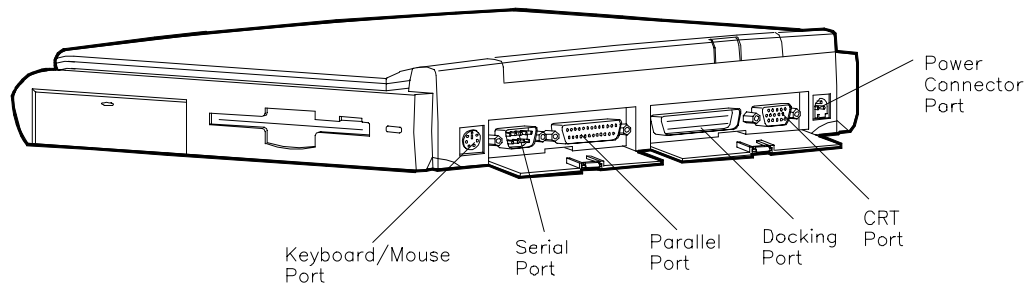

**Figure Section 2-3 Versa 2000 Series (Rear View)**

## Liquid Crystal Display (LCD)

The system integrates a built-in LCD. The LCD supports VESA Local (VL) bus video. The LCD operates with the Chips & Technologies 65545B1-5 VGA controller. The controller supports Super VGA. For more information on the 65545B1-5 VGA controller, read the description provided in the Versa 2000 Series Chip Set subsection.

The Versa 2000 series system features the following types of LCDs.

- TFT — 9.5-inch thin-film transistor backlit color LCD, 0.3 mm dot pitch, 12-bit digital interface, 640 x 480 resolution, 4,096 colors, (64K colors on an external CRT).
- DSTN — 10.4-inch dual-scan super twisted nematic color LCD, 0.3 mm dot pitch, 12-bit digital interface, 600 x 480 resolution, (64K colors on an external CRT).

In addition, the CRT port on the system's rear panel allows the user to connect an optional monochrome or color external display to the system. The computer supports the LCD and external display simultaneously.

Power-saving features for controlling the LCD's backlighting include the ROM-based hot key Fn F5, and Auto Setup power management settings. See Section 2, Setup and Operation, for information on using these settings. In addition, the automatic LCD status sense feature conserves the backlight. When the LCD is closed the backlight shuts off, saving battery power.

## **System Board**

The system board (G8TZL) is the primary component in the system. It contains I/O subsystems and houses the Intel<sup>®</sup> 486 DX4-75 chip (75 Mhz internal, 50 Mhz external). The chip controls important functions including power management, direct drive bus interface and memory management.

System board specifications are listed in Table Section 2-8 at the end of this section.

## **Battery Pack**

The system uses a rechargeable lithium-ion (Li-ION) battery as its transient power source. The battery pack installs in the compartment next to the diskette drive assembly. The battery uses 14.4 volts with a 2700 mAh capacity.

The battery pack powers the Versa 2000 for up to approximately four hours under power management, and two hours without power management. In addition, the battery pack lets the user know how much battery power is available via the LEDs on the front of the system, or the battery gas gauge in Windows.

When battery power is getting low, connect the AC adapter to a wall outlet and recharge the battery. It takes 1.6 hours to recharge the battery pack when the system is powered off. It takes 6 to 9 hours to recharge the battery while the system is powered on.

## **CMOS Battery**

The lithium battery (3.6 Volts, 1000 mAh capacity) is connected to CN17A on the system board. It provides battery backup and prevents data loss in the system's complementary metal oxide semiconductor (CMOS) RAM. This memory area contains information on the system's configuration like date, time, drives, and memory. The CMOS battery lasts approximately two years.

## **Bridge Battery**

The bridge battery saves the memory contents and system status for up to 5 minutes while in Suspend mode. It is connected to the system board via CN 13. The AC adapter maintains voltage in the bridge battery when the system is powered on or off. The bridge battery provides 10 Volts, 30 mAH.

## **PCMCIA Slots**

The Versa 2000 provides a 3.3 volt interface for either two Type I/Type II PCMCIA cards, or one Type III PCMCIA card.

---



## **Keyboard**

The built-in, 83-key keyboard (U.S) or 79-key keyboard (UK and Germany) uses the standard QWERTY format. The keyboard provides 12 function keys and 8 cursor control keys, with an Fn key for ROM-based key functions. The numeric keypad is embedded in the standard key layout.

## **NEC VersaGlide**

The NEC VersaGlide is a built-in mechanism that functions as the system's mouse. It controls the on-screen pointer (cursor). To use the VersaGlide, glide your finger across the NEC VersaGlide pad, and the cursor follows. The buttons on either side of the NEC VersaGlide allow the user to select or deselect menu items. Double-tap is also supported on the VersaGlide pad.

The NEC VersaGlide is the system's default pointing device unless a PS/2 mouse is installed. If an external mouse is installed, then the NEC VersaGlide is deactivated. A serial mouse is not supported.

## **SYSTEM MEMORY**

The system board provides either 4- or 8-MB of standard random access memory (RAM). Base memory is 640 KB and extended memory is 3072 or 7168 KB (interleaved), depending on the system model.

Optional memory cards with a value of 4-, 8-, or 16-MB can be added to increase system memory up to a maximum of 36- or 40-MB. In addition, 256 KB of read-only memory (ROM), 1 x 28F020, enables the system BIOS to be flashed.

---

## Memory Map

The system supports system and video shadowing, both controlled through complementary metal oxide semiconductor (CMOS). The system supports BIOS as a cacheable area with write protection. Table Section 2-1 lists the system's memory map.

To view a more complete breakdown, and to determine available space for the addition of drivers etc., type **MSD** at the DOS prompt and press **Enter**.

**Table Section 2-1 Versa 2000 Series System Memory Map**

Memory Space	Size	Function
017FFFFFh-01400000h	24 MB	Reserved for Extended Memory
017FFFFFh-01000000h	20 MB	Reserved for Extended Memory
00FFFFFFh-00C0000h	16 MB	Reserved for Extended Memory
00BFFFFFFh-00400000h	8 MB	Base Memory
003FFFFFFh-00100000h	4 MB	Base Memory
000FFFFFFh-000E0000h	128KB	ROM BIOS Low System & Video
000DFFFFFFh-000D0000h	—	
000BFFFFFFh-000A0000h	128 KB	Video Memory
0009FFFFFFh-000C0000h	—	

## SYSTEM VIDEO

The system's LCD operates using the Chips and Technologies 65545B1-5 VGA Controller. Video signals travel from the controller through the system's 15-pin D-SUB connector using 5 volts.

System video integrates a 32-bit VL-bus interface using local bus video. The system ships with 1 MB Video RAM (VRAM). It also supports video modes up to 1024 x 768 with 256 colors in CRT mode.

Table Section 2-2 lists CRT display modes..

---

**NOTE:** Interlaced video modes are represented with the letter I in the table below.

---

**Table Section 2-2 CRT Display Mode (CRT only)**

Mode (Hex)	Display Mode	Colors	Text Display	Resolution	Font	Refresh Rate
0, 1	Text	16	40x25	320x200	8x8	70
0*, 1*	Text	16	40x25	320x200	8x14	70
0**, 1**	Text	16	40x25	360x400	9x16	70
2*, 3*	Text	16	80x25	640x200	8x8	70
2**, 3**	Text	16	80x25	720x400	9x16	70
4,5*	Graphics	4	40x25	320x200	8x8	70
6	Graphics	2	80x25	640x200	8x8	70
7*	Text	Mono	80x25	720x350	9x14	70
7**	Text	Mono	80x25	720x400	9x16	70
D	Planar	16	40x25	320x200	8x8	70
E	Planar	16	80x25	640x200	8x8	70
F	Planar	Mono	80x25	640x350	8x14	70
10	Planar	16	80x25	640x350	8x14	70
11	Planar	2	80x30	640x480	8x16	60
12	Planar	16	80x30	640x480	8x16	60
12***	Planar	16	80x30	640x480	8x16	75
13	Packed Pixel	256	40x25	320x200	8x8	70
20	4-bit linear	16	80x30	640x480	8x16	60
22	4-bit linear	16	100x37	800x600	8x16	60

**Table Section 2-2 CRT Display Mode (CRT only)**

<b>Mode (Hex)</b>	<b>Display Mode</b>	<b>Colors</b>	<b>Text Display</b>	<b>Resolution</b>	<b>Font</b>	<b>Refresh Rate</b>
24	4-bit linear	16	128x48	1024x768	8x16	60
24I	4-bit linear	16	128x48	1024x768	8x16	43
30	8-bit linear	256	80x30	640x480	8x16	60
30***	8-bit linear	256	80x30	640x480	8x16	75
32	8-bit linear	256	100x37	800x600	8x16	60
32***	8-bit linear	256	100x37	800x600	8x16	75
34	8-bit linear	256	128x48	1024x768	8x16	60
34I	8-bit linear	256	128x48	1024x768	8x16	43
40	15-bit linear	32K	80x30	640x480	8x16	60
41	16-bit linear	64K	80x30	640x480	8x16	60
60	Text	16	132x25	1056x400	8x16	68
61	Text	16	132x50	1056x400	8x16	68
6A, 70	Planar	16	100x37	800x600	8x16	60
6A*** 70***	Planar	16	100x37	800x600	8x16	74
72, 75	Planar	16	128x48	1024x768	8x16	60
72I, 75I	Planar	16	128x48	1024x768	8x16	43
78	Packed Pixel	256	80x25	640x400	8x16	70
79	Packed Pixel	256	80x30	640x480	8x16	60
79***	Packed Pixel	256	80x30	640x480	8x16	74
7C	Packed Pixel	256	100x37	800x600	8x16	60
7C***	Packed Pixel	256	100x37	800x600	8x16	75

\*EGA Extension  
 \*\*VGA Extension  
 \*\*\*High Refresh Modes

Table Section 2-3 lists 640 x 480, TFT simultaneous LCD/CRT display modes.

**Table Section 2-3 LCD Display Modes (640 x 480 TFT, Simultaneous CRT)**



Mode (Hex)	Display Mode	Colors	Text Display	Resolution	Font	Refresh Rate
0,1	Text	16	40x25	320x200	8x8	60
2,3	Text	16	80x25	640x200	8x8	60
0*, 1*	Text	16	40x25	320x350	8x14	60
2*, 3*	Text	16	80x25	640x350	8x14	60
0**, 1**	Text	16	40x25	320.x4000	8x16	60
2**, 3**	Text	16	80x25	640x400	8x16	60
4, 5	Graphics	4	40x25	320x200	8x8	60
6	Graphics	2	80x25	640x200	8x8	60
7*	Text	Mono	80x25	640x350	8x14	60
7**	Text	Mono	80x25	640x400	8x16	60
D	Planar	16	40x25	320x200	8x8	60
E	Planar	16	80x25	640x200	8x8	60
F	Planar	Mono	80x25	640x350	8x14	60
10	Planar	16	80x25	640x350	8x14	60
11	Planar	2	80x30	640x480	8x16	60
12	Planar	16	80x30	640x480	8x16	60
13	Packed Pixel	256	40x25	320x200	8x8	60
20	4-bit linear	16	80x30	640x480	8x16	60
30	8-bit linear	256	80x30	640x480	8x16	60
40	15-bit linear	32K	80x30	640x480	8x16	60
41	16-bit linear	64K	80x30	540x480	8x16	60
78	Packed Pixel	256	80x25	640x400	8x16	60

\*EGA Extension

\*\*VGA Extension

Table Section 2-4 lists LCD display modes, 640 x 480 DSTN, simultaneous CRT display modes.

**Table Section 2-4 LCD Display Mode (640 x 480 DSTN, Simultaneous CRT Display)**

Mode (Hex)	Display Mode	Colors	Text Display	Resolution	Font	Refresh Rate
0, 1	Text	16	40x25	320x200	8x8	60
2, 3	Text	16	80x25	640x200	8x8	60
0*, 1*	Text	16	40x25	320x350	8x14	60
2*, 3*	Text	16	80x25	640x350	8x14	60
0**, 1**	Text	16	40x25	320x400	8x16	60
2**, 3**	Text	16	80x25	640x400	8x16	60
4,5	Graphics	4	40x25	320x200	8x8	60
6	Graphics	2	80x25	640x200	8x8	60
7*	Text	Mono	80x25	640x350	8x14	60
7**	Text	Mono	80x25	640x400	8x16	60
D	Planar	16	40x25	320x200	8x8	60
E	Planar	16	80x25	640x200	8x8	60
F	Planar	Mono	80x25	640x350	8x14	60
10	Planar	16	80x25	640x350	8x14	60
11	Planar	2	80x30	640x480	8x16	60
12	Planar	16	80x30	640x480	8x16	60
13	Packed Pixel	256	40x25	320x200	8x8	60
20	4-bit linear	16	80x30	640x480	8x16	60
30	8-bit linear	256	80x30	640x480	8x16	60
78	Packed Pixel	256	80x25	640x400	8x16	60
79	Packed Pixel	256	80x30	640x480	8x16	60

\*EGA Extension

\*\*VGA Extension

## PARALLEL INTERFACE

The system's parallel interface integrates National's PC87334 chip. It uses a 25-pin D-subconnector that is Enhanced Capabilities Port (ECP) equipped. The port is located on the system's rear panel.

The user selects between three parallel interface modes using Auto Setup. These include unidirectional, bidirectional or enhanced. Unidirectional mode sends data output from the standard ISA port only. Bidirectional mode sends data using the standard ISA port or PS/2 technology. Enhanced mode enables high speed data transmission to occur using either the unidirectional or bidirectional modes.

The parallel port address is 378h and the interrupt level is IRQ07. Pin locations for the parallel interface are listed in Appendix A.

## SERIAL INTERFACE

The RS-232C serial port is a 9-pin connector on the system's rear panel. The serial port consists of a 16550 compatible serial port controller with a program.

able baud rate within 50/56000 bps. The serial port connects an RS-232C device or an external modem. The serial port address is 3F8h and the interrupt level is IRQ04.

## NEC VERSA 2000 SERIES CHIP SET

Refer to Table Section 2-5 for a quick summary of the chip types used in the system. See the Abbreviations section at the beginning of this manual for a translation of chip technologies.

***Table Section 2-5\_Versa 2000 Series Chip Types and Technologies***

Chip	Manufacturer	Description	Technology
P24C	Intel	75 MHz CPU	208-pin SQFP
PT86C786 or Sequoia-1 PT86C768A2	Pico Power	System Logic	176-pin TQFP
PT86C718	Pico Power	IDE Interface, Peripheral Controller, Interrupt Multiplexer	176-pin TQFP
N28F020-150	Intel	256k x 8 Flash ROM	32-pin PLCC
C&T65545B1-5	Chips & Technologies	VGA Controller	208-pin QFP
PC8733	National Semiconductor	Diskette Controller, IDE, Parallel Interface	100-pin FQFP
M5M44260ATP-7S	Mitsubishi	Keyboard Controller	40-pin TSOP
CL-PD6720	Cirrus Logic	PCMCIA Controller	208-pin FQFP

## **System Logic**

The PT86C786/PT86C718 Pico Power chips and the Sequoia-1 PT86C768A2 chip each consist of a 176-pin thin-quad flat-package. This chip controller supports fast graphics and I/O processing. The system logic controller adds the following features:

- built-in level 2 cache controller
- integrated active power management
- integrated battery management
- high performance DRAM controller.

## **Flash ROM**

The N28F020 flash ROM is a 32-pin, plastic lead chip carrier (PLCC). The chip allows easy updates to the system's BIOS if needed. More specifically, the ROM is flashed electronically, installing the latest BIOS revisions to the system. It is possible to reprogram the BIOS up to 100,000 times. See Section 2, Setup and Operation, for BIOS update procedures.

The N28F020 provides the system upgrade capability as well as the following:

- 2048-kilobit (kb) memory
- Quick-Pulse Programming Algorithm
- 150 nanoseconds (ns) maximum access time
- ETOX Nonvolatile flash technology
- CMOS low power consumption
- low noise feature.

## **ROM BIOS**

The system uses a Flash ROM known as the system's ROM BIOS to store machine language programs. The BIOS size is 256 KB, which consists of 96 KB system utility (PCMCIA, Auto Setup), 64 KB system BIOS, 32 KB video BIOS, 32 KB power management and 32 KB reserved.

The BIOS programs execute the power-on self-test (POST), initialize CPU controllers, and interact with the LCD indicator panel, diskette drive, hard drive, communication devices and peripherals. The system BIOS also contains Auto Setup and provides VGA controller support. The ROM BIOS is copied into RAM (shadowing) for optimum performance.

The ROM BIOS contains both the system and video BIOS. The system BIOS is located in the upper portion of the device, video BIOS is located in the lower portion. System BIOS is located between F000h-FFFFh.

---



The BIOS often changes after the product release to provide enhanced features or bug fixes. To acquire the latest BIOS release, the ROM is flashed electronically allowing the BIOS update to occur without removing the ROM. See Section 2, Setup and Operation, for BIOS upgrade procedures.

## **Peripheral Controller**

The PT86C718 chip controls the Peripheral Controller, IDE Interface, and Interrupt Multiplexer. The chip integrates performance and power-saving features while providing the following:

- 8-level 64-bit write buffer to VL bus
- interrupt multiplexing logic
- reset logic.

## **VGA Controller**

The video architecture is maintained using the C&T65545B1-5 Controller and support logic. The controller supports video standards including EGA and CGA.

This powerful circuitry provides the following features for the system via the controller and LCD:

- 1-MB VRAM
- true-color and high-color display capability with 640 x 480 resolution
- supports external CRT resolutions up to 1024 x 768
- hardware windows acceleration
- bit boundary block transfer
- simultaneous LCD/CRT display in 640 x 480 VGA display mode
- optional frame memory
- high resolution graphics support.

### ***Video Controller Architecture***

The video controller architecture is broken down into several modules. The five significant modules include the sequencer, CRT controller, graphics controller, attribute controller and dithering engine.

For example, the sequencer manages CPU and display memory timing. The CRT controller controls sync and timing signals. The graphics controller permits the flow of communication between the CPU data bus and the 32-bit internal data bus. The attribute controller produces a 4-bit wide video data stream that refreshes the display.

---

## **Diskette Controller, Serial Interface, Parallel Interface**

The PC8733 chip is a 100-pin plastic Thin Quad Flat Plastic (TQFP) chip. The controller changes 8-bit parallel data into serial data and writes the data to the diskette. Conversely, the serial data is transmitted from the diskette into parallel data, where it remains until the read operation takes place.

Additional PC8733 chip operations include:

- compatibility with ISA, EISA, and Micro channel architectures
- low-power CMOS with enhanced power-down mode
- supports new 2 Mbps tape drives

## **Keyboard Controller**

The keyboard controller (M5M44260ATP-7S) supports a PS/2-style keyboard, mouse and security features such as keyboard hot keys and password. Refer to Appendix A for keyboard interface connector pin assignments.

When data is written to the output buffer, the controller generates an interrupt (IRQ01 or IRQ12) and requests the CPU to receive the data. The controller automatically adds an even parity bit to the data sent and waits for a response. The device must acknowledge that the data was successfully received by sending a response to the controller for each byte of data received.

## **PCMCIA Controller**

The controller (CL-PD6720) interfaces with the ISA bus, PCMCIA card socket and configuration registers to provide:

- memory address mapping, I/O address mapping
- power management for each PCMIC A card socket, controlled through power and RESETDRV control registers
- the elimination of interrupt conflicts using interrupt steering.

For a list of PCMCIA drivers and utilities, refer to the CARDSOFT directory on the C: drive.

---

## I/O Addressing

The CPU works in conjunction with I/O devices using I/O mapping. Refer to Table Section 2-6 for hex addresses.

**Table Section 2-6 Versa 2000 Series I/O Address Map**

Address (Hex)	I/O Device Name
000-00F	DMA Controller 1
020-03F	Interrupt Controller 1
040-043	Timer 1
048-04B	Timer 2
060-064	Keyboard Controller, 8042
061	NMI Status
070	NMI Mask
070-076	Real-time Clock
081H-083H	DMA Page Register
087H	DMA Page Register
089H-08BH	DMA Page Register
08FH	DMA Page Register
092H	Port 92
0C0H-0CEH	DMA Channel
0D0H-0DEH	DMA Controller 2
0102H	Parallel Port Configuration
0278H-027AH	LPT2 Data Port
02F8H-02FFH	Serial Controller Port B
0372H-0377H	Diskette Drive Controller
0378H-037AH	LPT1
03BCH-03BEH	LPT3
03F0H-03F5H	Diskette Drive Controller Port Status
03F8H-03FFH	Serial Controller Port A
0461H	Port 461 EISA mode
0C00H	Extended System Port 1
0C01H	Extended System Port 2
0C02H	Extended System Port 3
0C03H	Extended System Port 4

**Table Section 2-6 Versa 2000 Series I/O Address Map**

Address (Hex)	I/O Device Name
0C10H	Extended System Port 6
03E0-03E1	PCMCIA (CL-PD6720)

## Interrupt Controllers

Using interrupts, it is possible to change the code sequence. To change the sequence, reassign the interrupt-levels. Fifteen interrupts can be used with a cascade connection of 8259INTC x 2.

Interrupt-level assignments 0 through 15 are listed in Table Section 2-7, in order of decreasing priority.

**Table Section 2-7\_Versa 2000 Series Interrupt Level Assignments**

Controller Master/Slave	Priority	Name	Device
Master	0	IRQ00	Counter/Timer 1
Master	1	IRQ01	Keyboard
Master	2	IRQ02	INT output from controller 2
Slave	3	IRQ08	Real-time Clock
Slave	4	IRQ09	Reserved
Slave	5	IRQ10	Reserved
Slave	6	IRQ11	Reserved)
Slave	7	IRQ12	PS/2 Mouse*
Slave	8	IRQ13	Math Coprocessor (built into CPU)
Slave	9	IRQ14	Hard Disk Controller 1
Slave	10	IRQ15	Reserved
Master	11	IRQ03	Serial Port 2 (Internal Fax Modem)
Master	12	IRQ04	Serial Port 1
Master	13	IRQ05	Reserved
Master	14	IRQ06	Diskette Drive Controller*
Master	15	IRQ07	Parallel Port 1*

\*Industry standard locations

## POWER MANAGEMENT OVERVIEW

The Versa 2000 series system uses power management features to prolong system battery life.

The CPU implements a System Management Interrupt (SMI) function that works transparently with the operating system and application software. When activated, the processor mode changes to real mode. Unique “SM-RAM” containing power management software is mapped at address 30000h-3FFFFh. This activity is inherent to the system and does not require any adjustment to the operating system or application software.

The power management program is located in ROM at location EA000h-0EFFFh. In on-board DRAM, the software is physically allocated at 0D0000h-0DFFFFh.

Use Auto Setup to select specific power management options. For information on how to select these options, see Section 2.

---

**NOTE:** Some power management features are unavailable when an NEC docking station is connected.

---

### System Power Management

The system power management consists of the following operation modes. These modes are:

- **Active Mode** — In active mode, the system uses maximum power. It operates with the default clock speed (75 MHz). The system continues to run at this speeds unless overwritten by the power management features.
- **Suspend Mode** — When the system is powered on, but not in use it enters into Automatic Suspend mode after a specified amount of time (default timeout is 10 minutes). This shut-down mechanism conserves system power while allowing the user to return to complete the work at any time.

Or, the system can be put into Suspend mode using the Suspend/Resume switch. Slide the switch to activate Suspend mode; slide again to resume active mode.

Suspend mode causes the CPU clock to stop, local devices to shut down, and register values to be stored in RAM. System RAM is put into a slow refresh state.

### Local Power Management

Use Auto Setup to select one of four power management settings for local devices. These include Longest Battery Life, Personal Setup, Maximum Performance and Off. The power management levels are also available during AC operation. See Section 2 for specific procedures on using Auto Setup to select the power management settings.

---

When set to Longest Battery Life, CMOS will set local device timeout values, a local stand-by timeout value, and a suspend timeout value to ensure the longest battery life. The Personal Setup setting enables end-users to set the timeout values of their choice. The Maximum Performance setting selects CMOS values that will provide minimal energy savings and a shorter battery life. The Off selection terminates all power management timers.

Local device timers in the system control power consumption in the LCD and Hard Disk Drive.

## **PLUG AND PLAY**

The NEC Versa 2000 has a Plug and Play functionality. This means you can suspend the system, add an external keyboard, mouse, or monitor, and when you resume working, the NEC Versa 2000 recognizes the devices that have been connected to it. Similarly, you can remove external devices in Suspend mode and the NEC Versa 2000 notices the difference when resumed.

---

**NOTE:** A plug and play operating system and BIOS are required for this option to work.

---

## SPECIFICATIONS

Table Section 2-8 provides a complete list of Versa 2000 series system specifications.

**Table Section 2-8\_ Specifications**

Item	Specification
<b>Chassis Configuration</b>	
Size	Width: 11.7 in. (300 mm) Depth: 9.1 in. (233.3 mm) Height: 1.9 in. (48.7 mm), 2.2 in. (56 mm) NEC Versa 2000C (TFT) Weight: 6.51lb (2.95 kg) (Exact weight depends on options) NEC Versa 2000D (DSTN) Weight: 6.31lb (2.86 kg) (Exact weight depends on options)
Keyboard	PS/2 compatible, 83-key standard (79-key for UK and Germany) (includes Fn Key for ROM-based functions)
Device Slots	One internal 2 1/2-inch x 0.75-inch high slot, left side access, for standard hard disk drive Two PCMCIA slots that support up to two optional cards-oriented one on top of the other, left side access One 3 1/2-inch x 0.75-inch high slot, right-side access, for standard battery pack One 3 1/2-inch x 0.75-inch high slot, right-side access, for standard 1.44 diskette drive Two memory slots for optional memory card, located on bottom of system One built-in or optional internal modem board slot, located on the bottom of the system
Power	100 to 240 Vac at 50 or 60 Hz Output Voltage — 19 V DC, 2200mA (40.3W)
Battery Pack	Weight — 1.16 lb (527.6 g) Voltage — 14.4 V Capacity — 2700 mAH Battery Life — 5.5 hours (under maximum power-save mode) Bridge Battery — Backs up memory contents up to 5 minutes using Suspend Mode

**Table Section 2-8 Specifications**

<b>Item</b>	<b>Specification</b>
Front Panel Controls	Power Switch Power Management Suspend/Resume Button Reset Switch Brightness Control Contrast Control (DSTN model only)
LEDs	Power Management Battery/AC Power Hard Disk Diskette Num Lock Caps Lock Scroll Lock
<b>System Board</b>	
CPU	P24C-75
Clock Speed	75 MHz
System Bus Speed	25 MHz
Flash ROM	256 KB: N28F020 System Utility: 96 KB System BIOS: 64 KB Video BIOS: 32 KB Power Management: 32 KB Reserved: 32 KB
Connector Support	6-pin PS/2 External Keyboard/Mouse Connector 9-pin Serial Connector 25-pin Parallel Connector 198-pin Docking Connector 15-pin CRT Connector 4-pin DC-In Power Connector 36-pin Internal Memory Connector 25-pin IDE Connector (2) 26-pin Diskette Drive Connector



**Table Section 2-8 Specifications**

<b>Item</b>	<b>Specification</b>
<b>Memory</b>	
System Memory	4 MB high-speed interleaved access, 70 ns (DSTN model) 8 MB high-speed interleaved access, 70 ns (TFT model)
Optional	Two memory slots available for memory cards on underside of system.  Expandable in 4-MB, 8-MB, 16-MB  Maximum 36 MB to 40 MB total
Video RAM	1 MB
<b>Video Interface (VGA)</b>	
	9.5-inch Thin Film Transistor, (TFT), cold cathode fluorescent tube (CCFT) backlit color  10.4-inch Dual-scan Super-Twisted Nematic (DSTN) color  1-MB VRAM standard  Interface — Super VGA  Resolution — 640 x 480 pixels  Dot Pitch — 0.30 mm x 0.30 mm (0.012 in. x 0.012 in.)  Viewing Area — 192 mm x 144 mm (7.56 in. x 5.67 in.)  Aspect Ratio — 4:3 (or true CRT aspect ratio)
<b>Internal Device Support</b>	
Diskette Drive	3 1/2-inch, 1.44-MB (thin-height)
Hard Disk Drives	IDE interface (built-in), 2 1/2-inch x 1-inch high (thin-height)  System ships with the 350- or 540-MB Hard Disk Drive
<b>External Device Support</b>	
CRT	Displays up to 1024 x 768 resolution x 256 colors
Mouse	PS/2-compatible mouse
Keyboard	PS/2-compatible
<b>Software</b>	
Standard	MS-DOS <sup>®</sup> version 6.2.2 (also provided on diskette)  Windows <sup>®</sup> for Workgroups version 3.11 (also provided on diskette)  Windows 3.1 Keyboard Drivers and Advanced Power Management Drivers

**Table Section 2-8 Specifications**

<b>Item</b>	<b>Specification</b>
<b>Recommended Environment</b>	
Operation	Temperature: 41° to 95°F (5° to 35°C) Relative Humidity: 20% to 80% (No condensation)
Storage	Temperature: -4° to 104°F (-20° to 40°C) Relative Humidity: 20% to 80% (No condensation)
<b>Administrative Compliance</b>	
UL 1950 CSA C22.2 No. 950 (D3) (C-UL) TUV EN60950 CE EN60950 BSi AS (AC Adapter only) TUV / GS	

## Section 2

### Setup and Operation

This section provides setup and operation information for the Versa 2000 series system (including cabling, power-on verification and using Auto Setup).

#### UNPACKING THE SYSTEM

Find an area away from devices that generate strong magnetic fields (electric motors, transformers, etc.). Place the shipping carton on a sturdy surface and carefully unpack the system. The carton contents include the system, AC adapter, AC power cord, battery, software diskettes, and user documentation.

#### SETUP

When connecting power and signal cables, do the following.

1. Make sure that the system is powered off.  
  
The power switch turns the system on or off. Slide the switch right to turn it on, slide the switch again to turn it off.
2. Observe connector alignment marks and keys (when present).
3. Connect the AC adapter cable to the power connector port as shown in Figure Section 2-4.
4. Connect the end of the power cord to the AC input connector on the AC adapter.
5. Connect the other end of the power cord to an AC power source.

---

**NOTE:** If operating the system on DC power, verify that the system has a charged battery pack installed. For information on connecting the AC adapter to recharge the battery pack during or after use, see “Recharging the Battery Pack” in the following section.

---

6. Ensure that all connections are properly seated and secure.
  7. When removing or replacing cables, grasp and pull gently on the attached connectors.
-

## Cable Connections

Figure Section 2-1 shows the external cable connections for the system. Where appropriate, secure cables by tightening the cable holding screws.

Table Section 2-1 describes the I/O connectors on the rear of the system. For pin assignments, see Appendix A.

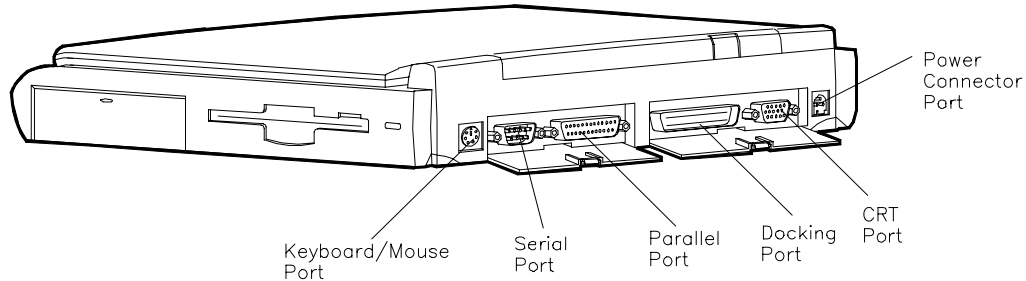

**Figure Section 2-1 Power and I/O Connector Locations**

**Table Section 2-1 I/O Connector Descriptions**

I/O Connector	Function
Keyboard/Mouse Port	Connects to a 101-key, external PS/2-style keyboard, or PS/2-style mouse.
Serial Port	Connects to an RS-232C device.
Parallel Port	Connects to a 25-pin parallel printer.
CRT Port	Connects to a 15-pin external CRT.
Docking Connector	Provides a 75-pin connector to attach the optional NEC MediaDock 2000.
Power Connector	This 4-pin connector provides an interface for the AC adapter. The AC adapter is then connected to a wall outlet via the AC power cord.

## OPERATING CONTROLS

The following section describes system controls, the LEDs, and function keys.

Refer to Figure Section 2-2 and Table Section 2-2 to locate system controls and switches.

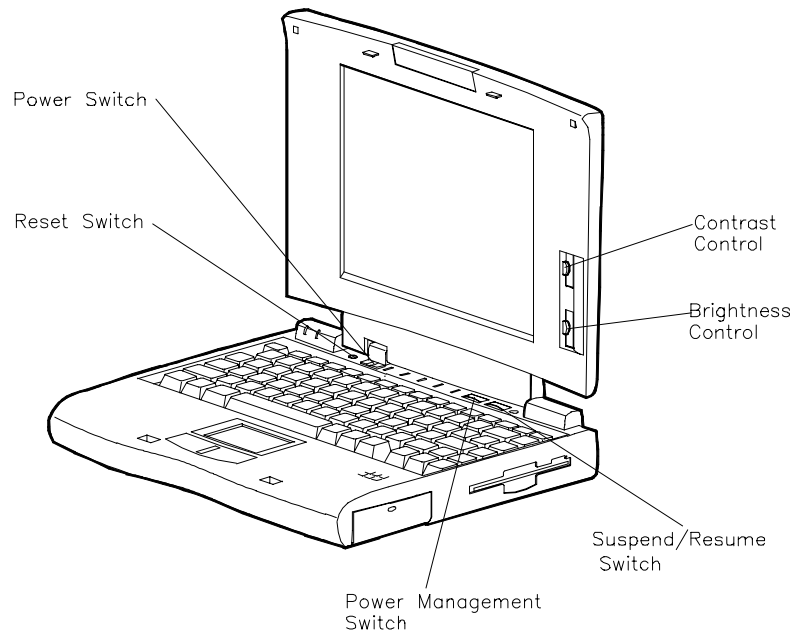

Figure Section 2-2 Control and Switch Location

**Table Section 2-2 Control and Switch Functions**

<b>Control</b>	<b>Function</b>
Reset Switch	Resets the system if the NEC Versa does not respond to keyboard input or VersaGlide movement. Use this control before powering down the system and restarting it.
Power Switch	Turns the system on when pushed to the right. Turns the system off when pushed to the right again.
Keyboard Select Switch	When on, selects the U.S. keyboard. When off, selects the United Kingdom, German Keyboard. The switch is located in the memory compartment on the bottom of the system.
Power Management	Turns Power Management on when pushed to the right. Turns Power Management off when pushed to the right again.
Suspend/Resume	Slide the switch for Suspend mode, slide again to resume active mode.
Contrast Control	Adjust the dark/light background on the LCD using this switch (on DSTN models only).
Brightness Control	Move the control upward to increase brightness on the LCD. Lower the control to decrease brightness on the LCD. A brighter adjustment uses more battery power. For longer battery life, decrease the brightness.

## **LEDs**

The NEC Versa 2000 uses LEDs to let the user determine system status. The following list describes LEDs.

**Hard Disk** — Green when the system is writing data to or retrieving from the system's hard disk.

**Diskette** — Green when the system is writing data to or retrieving from the diskette in the A drive.

**Power Management** — Green when power management is in use. No color when power management is off. Blinking green when the system is in Suspend mode.

---

Battery Status — There are several light indicators as follows.

<b>Battery Status</b>	<b>LED</b>
AC Powered	Green
50% to 100%	Green
25% to 49%	Yellow
10% to 24%	Orange
0% to 9%	Blinking Orange
Charging	Blinking Green
Power off	No color

Num Lock — Green is On; No color is Off.

Caps Lock — Green is On; No color is Off.

Scroll Lock — Green is On; No color is Off.

## Function Keys (Fn Keys)

Function keys set specific system parameters and are built into the ROM. When using these keys, simultaneously press **Fn** and the corresponding function key. See Table Section 2-3 for a list of ROM-based hot keys. ROM-based hot keys change system parameters temporarily. Hot Key functions operate until the system is turned off or reset.

**Table Section 2-3 FnKey Operations**

<b>Key</b>	<b>Function</b>
Fn F2	Highlight, toggles the contrast between standard and full.
Fn F3	LCD/CRT, toggles between LCD and CRT modes.
Fn F5	Backlight, toggles the backlight between standard and full
Fn F6	Speaker Volume, turns speaker volume on/off.
Fn F7	Power Management (P/M), sets P/M levels to highest performance, longest battery life, custom values, or off.
Fn F12	Scroll/Lock On/Off

## CMOS Clear Switch and Keyboard Switch

The CMOS clear switch is a slide switch located in the memory expansion compartment on the bottom of the Versa 2000 series system. Use this switch to clear all CMOS settings including date, time, and system parameters. For example, use the CMOS clear switch if a user forgets their system password, or during a troubleshooting session. Figure Section 2-3 shows the CMOS switch location.

To clear the CMOS switch, do the following:

1. Power off the NEC Versa 2000 and remove the expansion memory compartment cover.
2. Slide the CMOS Clear switch to On and wait about 30 seconds.
3. Switch CMOS Clear back to Off.
4. Replace the expansion memory compartment cover and power on the NEC Versa 2000.

The keyboard switch is also located in the memory expansion compartment on the bottom of the Versa 2000 series system. Set this switch as follows to select the appropriate keyboard type:

- On — U.S. Keyboard
- Off — United Kingdom, German Keyboard

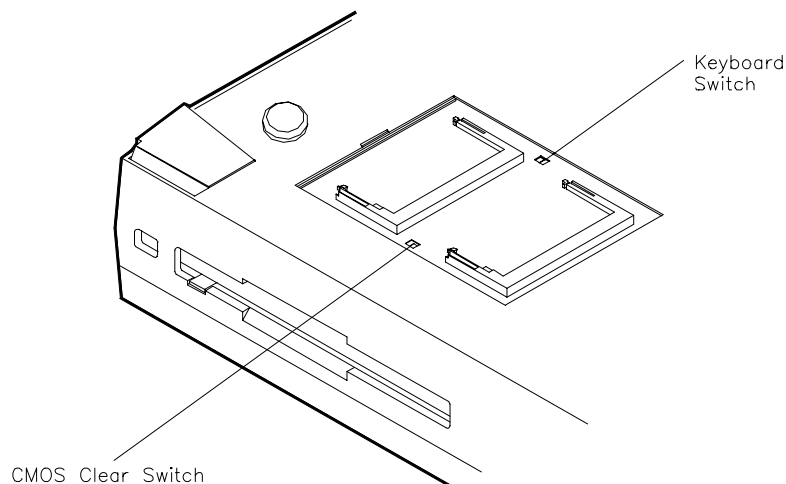

**Figure Section 2-3 CMOS Clear and Keyboard Switch Locations**

---



## Smart Power Switch

Provides an automatic feature that prevents you from accidentally powering off the NEC Versa 2000, and losing your data while your system is in Suspend mode. The smart power switch senses that the system is in Suspend mode and prevents you from directly powering off the system when you press the power switch.

To power off the system from Suspend mode,

1. Press the Suspend/Resume button to make the system active.
2. Press the power button to turn off the system.

## POWER-ON SELF-TEST (POST)

Each time the system is powered on, the system checks the working status of components through an automatic power-on self-test (POST). The test checks the system configuration for any discrepancies. One beep means that POST is successful. If any problems in data transfer or hardware exist, an error message appears.

If the message is an Invalid Configuration message, press **F1** to enter Auto Setup. The system collects Auto Setup data and lists the changes detected in the current parameter settings. Press **Enter** to review the settings, and make any necessary corrections. For more complete information, see “Using Auto Setup to Select Parameters.”

If no error messages appear but the system still malfunctions, check the items in the list below.

- The power switch for each peripheral is on.
- All cables and power cords are tightly connected.
- The electrical outlet is working.
- The brightness and contrast controls for the display are adjusted properly.
- All options have been properly installed.

---

**NOTE:** If the system parameters (date, time, options, etc.) have not been entered for the present configuration, enter them when you complete the setup procedures (see “System Parameters” in this section).

---

## POST Errors

Error messages will appear during POST when configuration information does not match the settings stored in memory. Error message will also appear if the system loses the configuration information due to hardware failure.

Refer to Table Section 2-4 for a description of POST error messages.

**Table Section 2-4 POST Error Messages**

Message	Action
Diskette drive n failure	Drive n does not work or is improperly connected (drive n meaning either drive A or B). Check that drive n is securely connected and power is on. Press <b>F1</b> to start Auto Setup to check the diskette drive parameters. If a problem still exists, drive n might need repair.
Diskette read failure - press <b>F1</b> to run Auto Setup. Press any other key to retry boot.	Remove the diskette from drive A and press <b>F1</b> to start the system from the hard disk. Or, insert a bootable disk in drive A and press <b>F1</b> .
Non-system disk or disk error; replace and press any key when ready.	Remove the diskette from drive A and press any key to start the system from the hard disk.
No boot device available - press <b>F1</b> to run Auto Setup.	Press <b>F1</b> , start Auto Setup and change the hard disk type to the correct setting. Exit and save Auto Setup.
Invalid configuration information - run Auto Setup	One or more system configuration parameters are not properly set. Use Auto Setup to set them correctly. Exit and save to update the parameters. Connect the AC adapter to charge the battery.
Real-time clock failure	Set time and date using Auto Setup. Exit and save to update the parameters. Connect the AC adapter to charge the CMOS battery.
Time-of day not set - run Auto Setup	Set time and date using the Auto Setup. Exit and save to update the parameters.
Fixed disk failure	Press <b>F1</b> to start Auto Setup. Exit and save to update the parameters. If a problem still exists, check if the drive is installed properly.
Fixed disk controller failure	Press <b>F1</b> . Start Auto Setup. Exit and save to update the parameters. The hard disk controller is inoperable and requires repair.
Keyboard clock line failure	The keyboard requires repair.
Keyboard data line failure	The keyboard requires repair.
Keyboard controller failure	The keyboard requires repair.
Keyboard stuck key failure	A key is jammed. Remove any objects interfering with data entry. If the message remains, the keyboard requires repair.

---

**NOTE:** If a display related error occurs, it is indicated by beeps. Display related errors usually require a system board replacement.

---

## SYSTEM PARAMETERS

The system uses Auto Setup to set and view system parameters. During POST, Auto Setup detects current system parameters. Read the following subsections for specific uses and procedures on setting system parameters.

### Auto Setup

Auto Setup is a ROM-based program. It is functional when enabled (factory default). Auto Setup automatically detects current system parameters during the power-on self-test. It also provides the following functions:

- sets date and time
- signals any hardware discrepancies during POST via error messages
- identifies any parameter(s) changes by blinking double carets (>>)
- verifies optional memory installation
- integrates security features.

### Accessing Auto Setup

Auto Setup is available at power-on:

- after POST displays the memory test. Press **F1** when the cursor is a blinking block.
- after the system password is entered (if set)

If there is an error at POST, press **F1** to enter Auto Setup. Check that the hardware settings match the present configuration.



## ***Auto Setup Keys***

Refer to Table Section 2-5 for a description of Auto Setup Key functions.

***Table Section 2-5 Auto Setup Key Functions***

<b>Key</b>	<b>Function</b>
Tab	Moves cursor to another field in the menu. For example, pressing Tab moves the cursor up or down a list of current parameters.
Highlighted letter	Selects menu bar option or parameter with the highlighted letter.
Alt + down arrow	Opens window with a list of parameter settings.
Up or down arrow	Moves cursor up or down a list of parameter settings.
Esc	Exits window without changing parameter settings.
C	Saves parameter changes and closes the window. This function also opens the Auto Setup Comms menu on the main screen.
Enter	Saves parameter changes and closes the parameter window.

---

## AUTO SETUP PARAMETER OPTIONS

Refer to Table Section 2-6 for a complete list of the parameters selectable through Auto Setup. Parameter descriptions follow the table. Menu selections for Auto Setup are the same except where noted.

**Table Section 2-6 Auto Setup Parameter Options**

<b>Menu</b>	<b>Default Setting</b>
<b>Comms</b>	
Serial Port	3F8h — 3FFh/IRQ4 (COM1)
COM Port Plug and Play Option	Reconfigurable
Parallel Port	378 h — 37Fh/IRQ7 (LPT1)
LPT Port Plug and Play Option	Reconfigurable
Parallel Port Mode	Enhanced
<b>Modem Port</b>	2F8h — 2FFh/IRQ3 (COM2 enable)
<b>Internal Modem Port</b> Plug and Play Option	Reconfigurable
<b>Drives</b>	
Diskette Drive A	1.44 MB - 3 1/2-inch
Hard Disk Drive 1	Auto Defined Drive Type
Diskette Boot	Enable
<b>Keyboard</b>	
Typematic Rate	Normal
NumLock Boot Status	NumLock Off
System Password	Disable
Keyboard Lock HotKey	Disable
<b>Power</b>	
Power Management	Longest Battery Life
Power Management under AC	Disable
BackLight	Full
HighLight	Full
Resume on Modem Ring	Disable
Resume on Time of Day	Disable
<b>System</b>	
Plug and Play Operating System	Not Present
Quick Boot	Disable

**Table Section 2-6 Auto Setup Parameter Options**

<b>Menu</b>	<b>Default Setting</b>
Time/Date	
Time	HR:MIN:SEC
Date	MO/DAY/YEAR

## **Parameter Descriptions**

Read the following for an understanding of each parameter's function.

### **Comms**

This menu item changes the I/O address for the serial, parallel, and internal modem ports. Change the default address and interrupt level only if a conflict exists. The Comms menu also sets the parallel port mode, and allows configuration for Plug and Play.

For system security, disable a port entirely by selecting the “Disable” setting.

### **Drives**

Sets the diskette drive and/or hard disk drive parameters, plus system security features. These parameters should be changed when a docking station is connected to the system or when the hard disk drive is replaced.

Specific drive menu options include the following:

- IDE Hard Disk Interface — Disables the built-in IDE controller, making the Docking Station II's IDE controller the primary controller if the system is docked.
- Diskette Boot — Allows user to disable booting from diskette drive, or enable booting from the diskette drive.

### **Keyboard**

This menu controls keyboard and password options. These options include:

- Typematic Rate — Sets the key repeat speed.
- NumLock Boot Status — Controls NumLock boot status at power-on.
- System Password — Sets the system password. The system boots only after the system password is entered.

Once the system password is set, the keyboard hotlock key can be enabled.

- Keyboard Lock HotKey — Sets Keyboard Lock HotKey security option.
-

## **Power**

Selects the power management features. Remember that these features are inoperative when the system is connected to the optional Docking Station.

Set the power management level to “Longest Battery Life” for maximum power savings, “Maximum Performance” for minimal savings, “Personal Setup” for customized power management, or “Off” to turn off all power management timers.

It is possible to customize the amount of time before local devices shut down to conserve power by setting these timeout values:

- Automatic Suspend
- Hard Disk Timer
- LCD Panel Timer.

The following power management options are available:

- Power Management Under AC — Normally, whenever AC power is connected to the Versa 2000, power management is disabled. Enabling this option allows the system to use the power management mode (high, custom, low, or off) that is set using the Power Management option.
- Power Management — Sets power management settings under battery power.
- System Suspend Mode — Suspend/Resume stores all necessary system information in RAM, shuts down all local devices, and stops the processor clock.
- BackLight — Sets the LCD backlight to standard or full.
- HighLight — Sets the character brightness to standard or full.
- Resume on Modem Ring — System automatically powers on when data is received via a modem.
- Resume on Time of Day — Enables the user to specify a time of day to automatically power on.

## **System**

Use this menu to add to the system's overall performance.

- Plug and Play operating system
  - Quick Boot — Reduces boot time by deleting unnecessary power-on self-tests.
-

## ***Time/Date***

Sets the current time and date in military format. To set the time, enter the hour, minute, and seconds in hh:mm:ss, 24-hour format. For example, type **14:30:00** for 2:30 p.m. Enter the current day, month, and year for example, mm/dd/yyyy. For example, to enter October 7, 1994, type **10/07/1994**.

Remember to type any preceding zeroes. For example, to enter 7:20 a.m., type **07:20:00**.

## **USING AUTO SETUP TO SELECT PARAMETERS**

Use the steps below to review or change system parameters.

1. When no error messages exist, choose a parameter option from the menu bar by pressing the appropriate highlighted character in the menu.

To select “Comms” press **C**. A window shows a parameter menu and the parameter's current setting. Go to step 3.

If an error message occurred during POST, use Auto Setup as follows:

- Note the blinking double carets (>>) that mark the changed parameter(s).
- Either accept the change(s) by pressing **Enter** and return to the Auto Setup Summary screen, or
- Change the parameter to the correct setting using the steps that follow.

2. Press **Tab** or the arrow keys to place the cursor on the parameter.

3. Press the **Alt ↓** to view the parameter settings. A list of parameter choices appears.

To select a setting, press **↓** to position the cursor on the appropriate setting. Press **Enter**. Auto Setup processes the change, exits the window and returns to the parameter menu.

Press **Esc** to return to the summary screen without saving changes.

4. Press **X** to exit the menu bar.
  5. Use **↓** to select “Exit and Save Changes” and press **Enter**.
  6. Press **Enter** again. The system reboots with the latest changes.
-



## SECURITY OPTIONS

The system supports two types of passwords for system security:

- system password
- keyboard lock hotkey.

The following contains instructions for setting and using the password feature.

### System Password

Use the system password to lock the system at power-on. The system password is set using Auto Setup. This locks the keyboard to prevent unauthorized access to the system. When a system password is set, the password must be entered before entering Auto Setup. This feature allows only authorized access to system parameters.

Set an initial password as follows.

1. Select the Keyboard menu option in Auto Setup.
2. Select “System Password” on the Keyboard parameter menu in Auto Setup.
3. Select “Enter and Enable”.
4. At the prompt, enter up to seven characters in length and press **Enter**. Another window appears with a prompt to re-enter the password for verification.
5. Re-enter the password and press **Enter**. Auto Setup returns to the Keyboard parameter menu.
6. Save the changes and return to the initial summary screen.
7. Exit Auto Setup and save the changes.

---

**NOTE:** Once a system password is entered, it cannot be edited or disabled in Auto Setup. See procedures for removing or replacing a password later in this section.

---

### *Using the System Password*

After setting the initial password, a password prompt appears each time the system is powered on. The password prompt is a key icon. The key icon appears after the completion of POST.

To use the password, boot the system by powering the system off and then on. At the password prompt (key icon), enter the password and press **Enter** to load the operating system or to enter Auto Setup.

---

---

**NOTE:** The characters entered do not appear on the screen.

---

If it takes more than three tries to enter the correct password, power off the system and try again.

Remove a password or replace a current password with a new one as follows.

- To remove a password, type at the password prompt the current password and a forward slash in the following format:

*current password/*

Press **Enter**. The password clears and the prompt no longer appears at power-on.

- To replace the current password with a new one, at the password prompt type the current password, a slash, and the new password in the following format:

*current password/new password*

Press **Enter**. The password changes to the new password. Enter the new password at the next power-on.

## Keyboard Lock Hotkey

The system supports a keyboard lock feature for additional security. The lock option appears on the Auto Setup screen only after you have enabled a password. At this point in Auto Setup, the lock can be enabled or disabled.

To lock the keyboard, press **Ctrl + Alt + Back Space**. To unlock the keyboard, enter the password. If the password is removed, this option is no longer available.

## NEC UTILITIES

To view the list of NEC utilities and drivers, go to the cardwiz directory. To get into the cardwiz directory, type **cardwiz**. Press **Enter**.

---

**NOTE:** Most applications, such as communications software, are not PCMCIA aware. Make sure the card is inserted and ready before using an application.

---

### BIOS Update Utility (BUU)

The BIOS Update utility updates the ROM BIOS version of the system. This software utility updates the Flash ROM installed on the system board. The utility identifies and saves the currently installed BIOS version before installing the new version.

To receive the latest BUU diskette (in the U.S. only), call the Technical Support Center at (800) 388-8888 or download the BUU by logging onto NEC's Electronic Bulletin Board System (BBS) and perform the procedures described in the following subsections.

To use the BIOS Update utility, the system configuration must be set to 640 KB of base memory with the programming voltage enabled.

#### ***Precautions***

The BIOS Update utility diskette saves the old BIOS version. Make sure the diskette is not write-protected. If attempting to use a diskette that has updated another unit, a message warns that the original BIOS may not be restored. If updating more than one system, first make a copy of the original diskette for each system before using the diskette.



## ***Downloading the Update Utility***

To receive the latest version of the BIOS Update utility, perform the following steps.

1. Log onto NEC's BBS by dialing (508)-635-4706. The BBS parameters are as follows.
  - Baud rate: 300 to 14,400 Kbps
  - Parity: none
  - Data bits: 8
  - Stop bits: 1
2. Once connected, a name and password must be entered. When connecting for the first time, a questionnaire must be completed.
3. At the NEC/Technologies Bulletin Board main menu, type **F** and then press **Enter** for the File Menu.
4. At the File Menu, type **D** and then press **Enter** for download.
5. Type the file name, **L440nB3.EXE**, and press **Enter**. Insert the correct revision number in place of the *n*.
6. Press **Enter** again.
7. Set the default protocol on the BBS.
8. The BBS displays a prompt that it is ready to send the file. Perform the software's download transfer procedure. The files are sent to the hard drive. Execute the file to create a bootable disk. A message prompts you to insert a 1.44-MB diskette drive in drive A. Make sure that it is a high-density diskette. Press any key to continue.

After pressing any key, the diskette is formatted and the BIOS update files are copied to the diskette.
9. After the download is completed, log off the BBS.

---

**NOTE:** If you don't know the filename, join the laptop conference to find the BIOS or driver disk you need.

---

## ***Using the Update Utility***

Load the BIOS Update utility as follows.

---

---

**CAUTION:** Never load a BUU from another system model. That system's BIOS will be lost.

---

1. Power off the system unit.
2. Insert the BIOS Update Utility diskette into drive A.
3. Power on the system unit. The unit boots and automatically loads the utility. A message similar to the following appears:

FLASH ROM EQUIPPED

WARNING: The BIOS Update Procedure  
is about to begin, press ENTER to continue.  
To abort, remove the diskette and reset the unit.

5. Press **Enter** to continue. The utility checks the currently installed BIOS version and the diskette's BIOS versions. If the BIOS can be updated, the Main Menu appears (see the following screen). If there is a problem, the appropriate message is displayed.



NEC BIOS Update Utility  
Main Menu

Information  
Display BIOS Version  
Customize BIOS  
Install New BIOS  
Restore Original BIOS  
Exit

## ***Menu Functions***

Use the Main Menu to update the BIOS version; other menu functions are optional. To select a menu function, use the arrow keys to highlight the function and press **Enter**. If help is needed, press **F1** for additional information.

### *Information*

This option provides important information about the BIOS Update utility. Read this information before proceeding with the utility.

### *Display BIOS Version*

Use this option to display the currently installed BIOS version and the version of the new replacement BIOS. A message similar to the following appears.

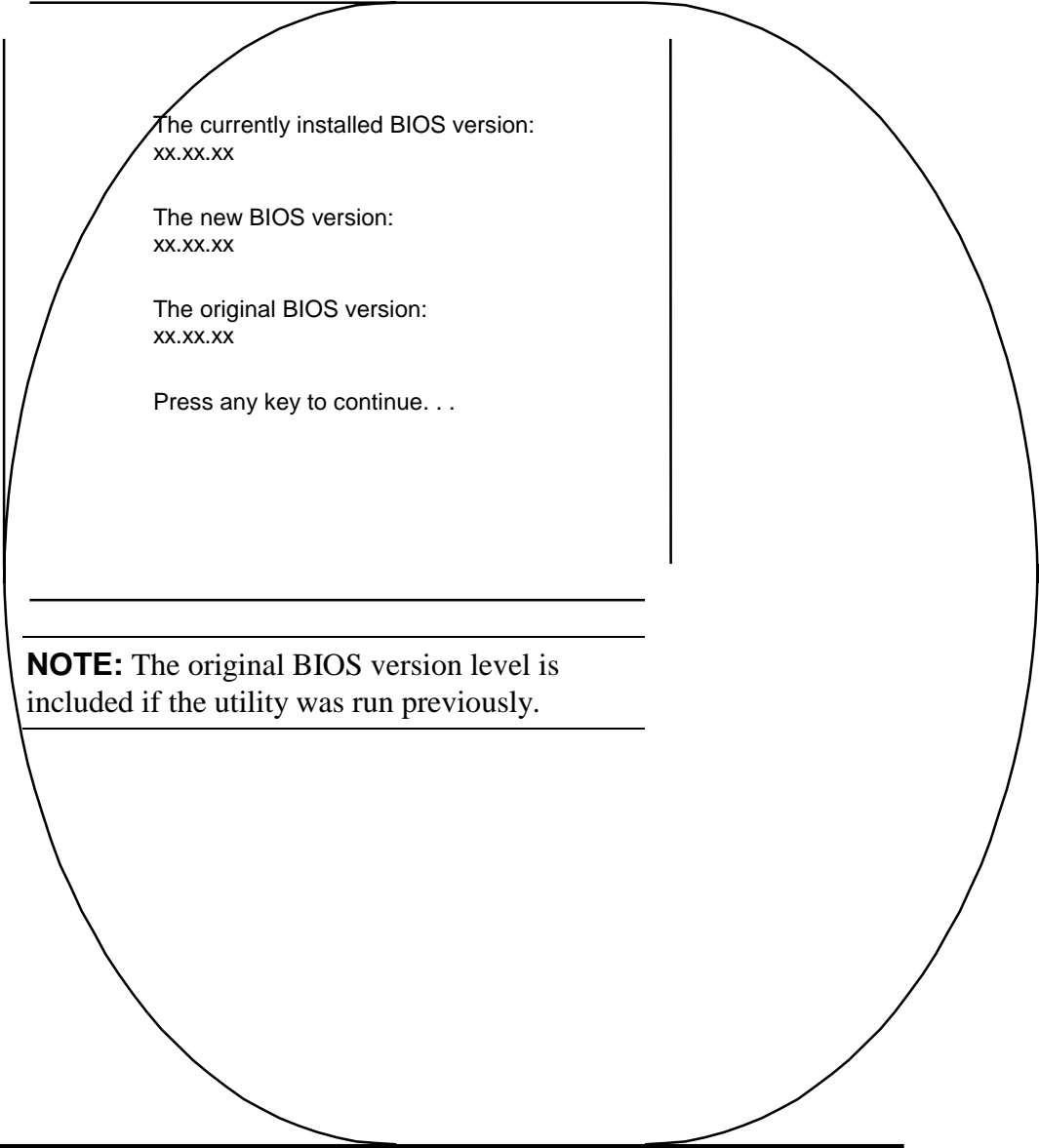

The currently installed BIOS version:  
xx.xx.xx

The new BIOS version:  
xx.xx.xx

The original BIOS version:  
xx.xx.xx

Press any key to continue. . .

---

**NOTE:** The original BIOS version level is included if the utility was run previously.

---

### *Customize BIOS*

Use this option to customize the BIOS when the new BIOS is installed. When selected, a message similar to the following appears.

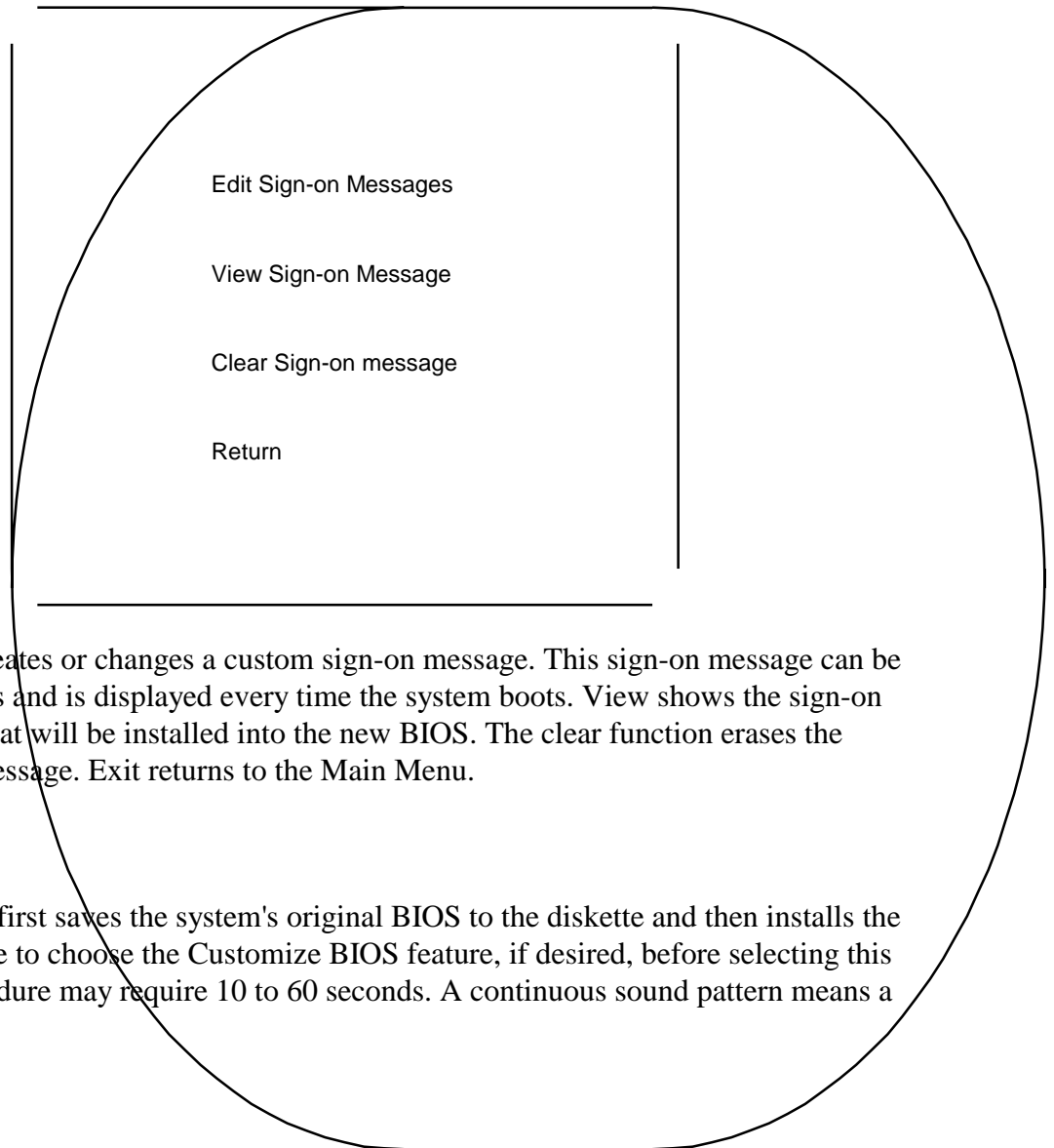

The edit option creates or changes a custom sign-on message. This sign-on message can be up to 40 characters and is displayed every time the system boots. View shows the sign-on message, if any, that will be installed into the new BIOS. The clear function erases the custom sign-on message. Exit returns to the Main Menu.

### *Install New BIOS*

This menu option first saves the system's original BIOS to the diskette and then installs the new BIOS. Be sure to choose the Customize BIOS feature, if desired, before selecting this option. This procedure may require 10 to 60 seconds. A continuous sound pattern means a failure.

When selecting the Install New BIOS function, a message similar to the following appears.

This procedure will install the new BIOS  
in your system.

After the new BIOS is installed, your system  
will be reset.  
Enter "Y" to continue [N]

Note: Your current BIOS will be saved if a  
copy of it does not already exist on this disk.

Warning: Do NOT disturb the system while  
update procedure is in progress.

The utility updates the BIOS and resets the system to make the new version operational. To reuse the utility, power the system off and back on again with the BIOS Update Utility diskette inserted in drive A.

#### *Restore Original BIOS*

Use this option to restore the previous BIOS from the update diskette. If the system BIOS was not updated, this function does nothing. A message indicates the new BIOS must be installed before the original BIOS can be restored.



This procedure installs the previously saved BIOS in the system. Selecting this function displays a message similar to the following.

This procedure installs the previously saved BIOS in your computer.

After the new BIOS is restored, your system is reset.  
Enter "Y" to continue [N]

Warning: Do NOT disturb the system while the restore procedure is in progress.

This procedure may require 10 to 60 seconds. A continuous sound pattern means a failure. The utility restores the previous BIOS and resets the system to make the previous version operational. To reuse the utility, power the system off and back on again with the BIOS Update Utility diskette inserted in drive A.

*Exit*

This option exits the utility and resets the system. Press **Esc** to return to the Main Menu. Press **Enter** to exit the utility.

## POWER SOURCES

For optimum performance and power conservation, use the AC adapter to power the Versa 2000 series system. Other power sources include the battery pack, the optional car DC adapter and the optional docking station .

### AC Adapter

The AC adapter allows the system to operate with AC power, recharges the battery pack, and maintains the bridge battery. The internal backup battery allows the system to retain system parameter information.

---

**NOTE:** Make sure that the AC adapter is connected at all times. It will continue to charge the battery pack and bridge battery during operation or when the system is turned off.

---

If the AC adapter is used primarily, remove the battery pack to reduce system weight.

---

**CAUTION:** Only use the AC adapter model provided with the Versa 2000 series system.

---

Connect the AC adapter as follows:

1. Connect the adapter's DC cable to the power connector on the rear of the system. Connect the other end to the AC adapter.

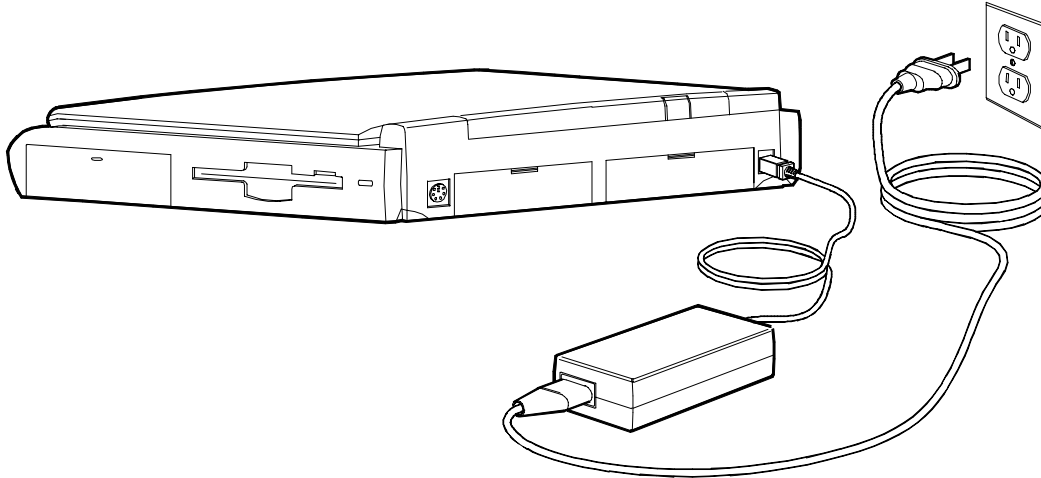

**Figure Section 2-4 Connecting the AC Adapter**

2. Connect one end of the AC power cable to the AC adapter. Connect the other end of the AC power cable to a 100- to 240-volt, AC wall outlet.

## **Battery Power**

It is highly recommended to use battery power only when an AC outlet is unavailable. A fully charged battery pack lasts approximately 5.5 hours under maximum power save mode, and 2.5 hours without power save mode.

The actual amount of battery time depends on the use of power-saving features, the application, options installed, and the environment.

Refer to the Battery Status table in the LEDs section for information on determining how much battery power is currently available.

---

### **Recharging the Battery Pack**

There are two ways to recharge the battery pack, Quick Charge and Normal Charge.

A Quick Charge is performed when the system is off or in Suspend mode with the AC adapter connected. A Normal Charge is performed when the AC adapter is connected and the system is on. When the battery status LED shows an orange light or blinking orange light, it is time to recharge the battery. .

To recharge the battery, simply attach the AC adapter to the system. Charging the battery pack with a Quick Charge takes 1.6 hours with power off. Charging the battery pack with a Normal Charge takes 6 to 9 hours with power on. These time increments assume that there are no options connected to the Versa 2000.

### **REPLACING THE BATTERY PACK**

To replace the battery pack with a fully charged battery, press the suspend button to activate Suspend mode. It is not necessary to turn off system power as long as Suspend mode is activated. The bridge battery maintains data and system status for up to 5 minutes while in Suspend mode. Use the steps below to install a charged battery pack.

1. If power is on, push the suspend switch to put the system in Suspend mode. The bridge battery saves the memory contents and system status.
2. Remove the battery cover.
3. Locate the battery release latch on the bottom of the system. Push the release latch while removing the battery pack from the compartment.

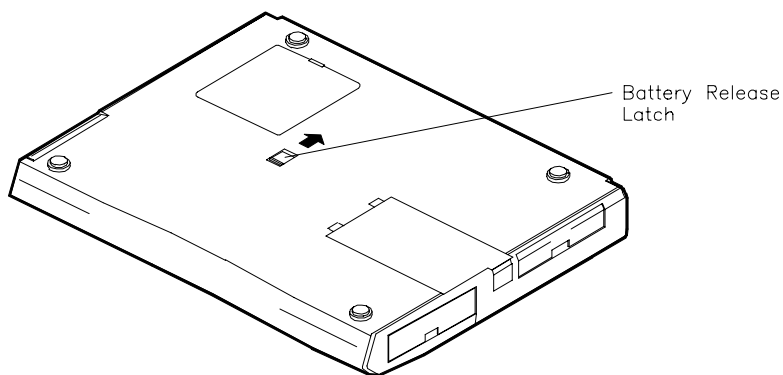

**Figure Section 2-5 Battery Release Latch Location**

---

4. Insert the new battery pack into the battery compartment. Push the battery pack into the compartment until it locks into place.

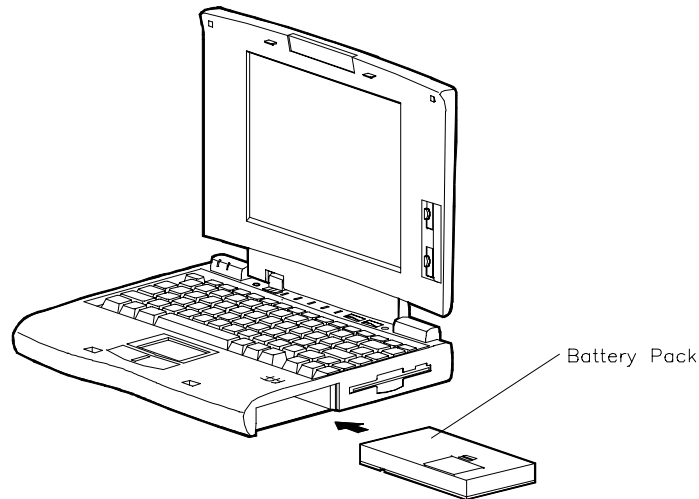

**Figure Section 2-6 Battery Pack Replacement**

3. Replace the battery cover.
4. Exit Suspend mode.

## **Saving Battery Power**

The system utilizes two power conserving states: Active and Suspend mode. The system automatically switches between these modes to conserve battery power and prolong battery life. To save additional power, use the following guidelines:

- put the system in Suspend mode when you need to leave the system for a short time
- reduce the LCD's brightness using the Fn F5 hot key to toggle the LCD backlight between standard or full
- turn off the system when not in use.

The system also integrates automatic power-saving features. Refer to Table Section 2-7 for a complete description.

---

## AUTOMATIC POWER-SAVING FEATURES

Table Section 2-7 lists the Versa 2000 series automatic power conserving features. These features work during battery and AC operation. The features listed below do not work when the optional docking station is connected. Battery life is also maintained by using the power management levels listed in the next section.

The default timeouts listed below can be changed using Auto Setup. The NEC Power Center Utility icon also allows you to change the timeout period for some of these devices.

Use the **Fn F7** key combination to set the power management level. You can toggle between Highest Performance, Longest Battery Life, Custom Values, and Off. You can modify the custom level for your specific working environment using Custom Values. Default values change depending on the type of power management you use.

**Table Section 2-7 Automatic Power-Saving Features**

Device	Default (timeout)	Description
LCD backlight	2 min.	When no keyboard or NEC VersaGlide input occurs for the specified timeout, the LCD backlight shuts off.
Hard Disk	1 min.	Hard disk motor stops when not accessed for specified timeout.
Suspend Mode	10 min.	The system enters Suspend mode after total system activity.

### Power Saving Levels

The power saving levels work transparent to system applications and can be set by the user through Auto Setup. See “System Parameters” earlier in this section for information on using Auto Setup to select power management levels. The two levels for conserving battery power are as follows.

#### **Active Mode**

The system uses full power. All components are turned on and active.

#### **Suspend Mode**

Suspend mode conserves power by shutting off all system components while storing RAM contents and system status. The system returns to Active mode when the suspend button is pressed or if an optional modem receives data.

---

## Section 3

### Illustrated Parts Breakdown

This subsection contains the illustrated parts breakdown (IPB) and NEC part numbers for the Versa 2000 series system. **Error! Reference source not found.** shows the field-replaceable parts for the system.

Table Section 3-8 lists option, documentation, and shipping carton part numbers.

---

**NOTE:** In the U.S., call 1(800) 388-8888 to order NEC spare parts. To order options in the U.S., call your local sales office.

---

**Table Section 3-8 Versa 2000 Series Field-Replaceable Parts\***

Item	Description	Part Number
1	Modem Cover	136-238077-001A
2	Modem Port Cover (small plastic)	136-619064-001A
3	Modem Board	808-874740-001A
4	PCMCIA Cover	136-238068-001A
5	Foot (left)	136-619045-001A
6	AC Power Cable	808-740591-001A
7	AC Adapter	808-891828-002A
8a	Versa 2000 Logo (DSTN)	158-030780-000
8b	Versa 2000 Logo (TFT)	158-030780-001
9a	Front Cover Assembly (bezel, DSTN)	136-619073-001A
9b	Front Cover Assembly (bezel, TFT)	136-619074-001A
10a	LCD Sub-assembly (DSTN)	136-238073-001A
10b	LCD Sub-assembly (TFT)	136-238074-001A
11	LCD Lock Shaft	136-619099-A
12	LCD Lock Spring	136-619083-A
13	LCD Lock	136-619082-001A
14	Screw Covers (rubber)	136-619087-A
15a	Top Case Assembly (TFT)	136-238070-002A

---

\* This data was prepared July 1995. For an up-to-date listing of spare parts, please call FastFacts (800) 366-0476 and order document number 42181268

---

**Table Section 3-8 Versa 2000 Series Field-Replaceable Parts\***

<b>Item</b>	<b>Description</b>	<b>Part Number</b>
15b	Top Case Assembly (DSTN)	136-238070-001A
16a	Keyboard (Domestic)	808-897250-004A
16b	Keyboard (German)	808-897250-003A
16c	Keyboard (United Kingdom)	808-897250-002A
17	Glidepoint Assembly	808-874649-003A
18	Speaker Assembly	808-874738-001A
19	Bridge Battery	804-021231-001A
20	Battery/Speaker Holder	136-619095-001A
21	Metal Keyboard Support	136-238071-A
22	CMOS Battery (Lithium)	808-874741-001A
23a	Main Board Assembly, 75 MHz/4 MB (DSTN)	136-238075-003A
23b	Main Board Assembly, 75 MHz/4 MB (TFT)	136-238075-004A
23c	Main Board Assembly, 75 MHz/8 MB(TFT)	136-238075-002A
24	1.44-MB Diskette Drive	808-874617-001A
25	Foot (right)	136-619046-001A
26	Serial/Parallel Connector Cover	136-238065-001A
27	Dock/Video Connector Cover	136-238066-001A
28	FDD Cable	808-874731-001A
29	Battery Cover	136-619059-001A
30	Main Battery	804-021230-001A
31	Bottom Case Assembly	136-238062-001A
32	Memory Cover (RAM)	136-238063-001A
33	Rubber Foot	808-814221-043A
34a	350-MB Hard Disk Drive	136-237726-001A
34b	540-MB Hard Disk Drive	136-237726-002A
34c	720-MB Hard Disk Drive	136-237726-003A
35	Hard Disk Drive Cover	136-238067-001A
36	GlidePoint Cable	808-874732-001A
37	Intel Inside Sticker	808-095733-001A
38	LED Cable	808-874735-001A
39a	LCD Cable (DSTN)	808-874733-001A
39b	LCD Cable (TFT)	808-874734-001A



**Table Section 3-8 Versa 2000 Series Field-Replaceable Parts\***

<b>Item</b>	<b>Description</b>	<b>Part Number</b>
40	Modem Cable	158-050519-005
41	NEC Logo Badge	136-600325-A
42*	Plastic Carrying Case	158-040505-000
43*	4-MB Memory Card	136-266472-A
44*	8-MB Memory Card	158-082642-070

\* Not shown in IPB figure

---

---

**Table Section 3-9 Option and Documentation Part Numbers \***

<b>Description</b>	<b>Model Number</b>
540-MB Hard Disk Drive	OP-220-60001
720-MB Hard Disk Drive	OP-220-60002
AC Adapter	OP-520-60001
NEC Versa 2000 Series MiniDock	OP-560-60001
Li-ION Battery Pack	OP-570-60001
2400/9600bps Data/Fax Modem	OP-710-4008
14.4Kbps Data/Fax Modem (PCMCIA)	OP-710-4009
5-MB Storage Card	OP-730-4202
NEC VersaPage PC-Card Pager	OP-710-4411
High Performance Ethernet Card	OP-720-1201
NEC VersaVideo Portable Digital Video Card	OP-750-4701-1
500 Kbps SCSI Card	OP-740-4001
NEC Versa 2000 Series Quick Setup Sheet	819-181280-000
NEC Versa 2000 Series User's Guide	819-181279-000
NEC Versa 2000 Series Service and Reference Guide	819-181268-000
Internal 14.4 Kbps Modem	OP-440-60001
PS/2 Y Adapter	OP-510-1201
Battery Charger	OP-570-60002

---

\* This data was prepared July 1995. For an up-to-date listing of spare parts, please call FastFacts (800) 366-0476 and order document number 42181268

---

## Section 4Appendix A

### Connector Locations and Pin Assignments

Figure Section 4-1 shows the connectors on the Versa 2000 series system board. Table Section 4-1 lists connector descriptions. The remaining tables provide pin assignments for system connectors.

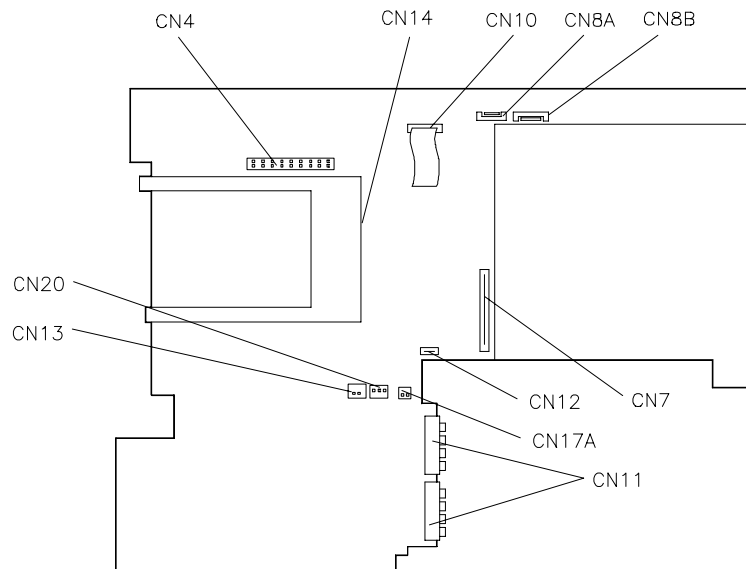

**Figure Section 4-1 System Board Connector Locations**

**Table Section 4-1 System Board Connectors**

<b>Connector</b>	<b>Description</b>
CN13	Bridge Battery
CN20	Speaker Connector
CN4	LCD Connector
CN14	PCMCIA Connector
CN10	LED Connector
CN8A and CN8B	Keyboard Connectors
CN7	Diskette Drive Connector
CN12	VersaGlide Connector
CN17A	Lithium Battery Connector
CN11	Battery Pack Connector

**Table Section 4-2 Keyboard/Mouse Connector Pin Assignments**

<b>Pin</b>	<b>Signal</b>
1	KeyboardData
2	MouseData
3	Ground
4	+5V
5	Keyboard Clock
6	Mouse Clock

---

**Table Section 4-3 Serial Port Connector Pin Assignments**

<b>Pin</b>	<b>Signal</b>
1	Data Carrier
2	Receive Data
3	Transmit Data
4	Data Terminal Ready
5	Ground
6	Data Set Ready
7	Request to Send
8	Clear to Send
9	Ring Indicator

**Table Section 4-4 CRT Connector Pin Assignments**

<b>Pin</b>	<b>Signal</b>
1	Red
2	Green
3	Blue
4	No Connection
5	Ground
6	Ground
7	Ground
8	Ground
9	+5V PnP VESA Vcc
10	Ground
11	No Connection
12	PnP VESA Data
13	Horizontal Sync
14	Vertical Sync
15	PnP VESA Clock

---

**Table Section 4-5 Parallel Printer Pin Assignments**

<b>Pin</b>	<b>Signal</b>
1	- Strobe
2	Data Bit 0
3	Data Bit 1
4	Data Bit 2
5	Data Bit 3
6	Data Bit 4
7	Data Bit 5
8	Data Bit 6
9	Data Bit 7
10	- Acknowledge
11	Busy
12	PE
13	Select
14	- Auto Feed XT
15	- Error
16	- Initialize
17	- Select In
18 -25	Ground

---

**Table Section 4-6 Docking Connector Pin Assignments**

<b>Pin</b>	<b>Signal</b>
1	+5V
2	+5V
3	DSDET2
4-23	Ground
24	DSDET2
25-32	+12V CHG
33	Docking Station Detect
34	AGND
35	AGND
36	AGND
37	TC
38	BALE
39	IOCHCK
40	IOCHRDY
41	AEN
42	SBHE
43	MEMR
44	MEMW
45	RESET DRV
46	OVS
47	SMEMR
48	SMEMR
49	IOR
50	IOW
51	IOCS16
52	PC Detect
53	HDD Access
54	FDD Access
55	Mouse Clock
56	Mouse Data
57	Keyboard Clock

---



**Table Section 4-6 Docking Connector Pin Assignments**

<b>Pin</b>	<b>Signal</b>
58	Keyboard Data
59	Reserved
60	+12V Sys
61	Floppy Track 0
62	Through
66	+12V Sys
67	CRT Red
68	CRT Green
69	SA17
70	SA18
71	SA19
72	MENCS16
73	Refresh
74	Printer-Strobe
75	Printer-Acknowlg
76	Printer-Busy
77	Printer-P End
78	Printer Select
79	Printer-Auto FD
80	Printer -Error
81	Printer-Initialize
82	Printer Select In
83	FD Head Select
84	FD-Direction In
85	FD-Boot Select
86	FD-Low Density
87	FD-Write Enable
88	FD-Step
89	LA23
90	LA22
91	LA21

---

**Table Section 4-6 Docking Connector Pin Assignments**

<b>Pin</b>	<b>Signal</b>
92	LA20
93	LA19
94	LA18
95	LA17
96	FD-Write Protect
97	FD-Disk Change
98	FD-Read Data
99	FD-Index
100	CRT-Blue
101	CRT-HSync
102	SD8
103	SD9
104	SD10
105	SD11
106	SD12
107	SD13
108	SD14
109	SD15
110	Master
111	Serial-CD
112	Serial-TXD
113	Serial-RXD
114	Serial-DTR
115	Serial-DSR
116	Serial-RTS
117	Serial-CTS
118	Serial-RI
119	FD-Drive Select
120	FD-Motor 0
121	SD7
122	SD6
123	SD5

---

**Table Section 4-6 Docking Connector Pin Assignments**

<b>Pin</b>	<b>Signal</b>
124	SD4
125	SD3
126	SD2
127	SD1
128	SD0
129-132	Reserved
133	CRT-VSync
134	CLK1
135	PR-D2
136	PR-D4
137	PR-D6
138	IRQ3
139	IRQ5
140	IRQ7
141	IRQ10
142	IRQ12
143	IRQ15
144	DRQ1
145	DRQ3
146	DRQ6
147	DACK0
148	DACK2
149	DACK5
150	DACK7
151	FD-Drive Select 1
152	FD-Motor 1
153	FD-Write Data
154	SA15
155	SA13
156	SA11
157	SA9
158	SA7

---

**Table Section 4-6 Docking Connector Pin Assignments**

<b>Pin</b>	<b>Signal</b>
159	SA5
160	SA3
161	SA1
162	Audio Analog Ground
163	Audio Analog Ground
164	Line-in Right
165	Line-in Left
166	PR-D0
167	PR-D1
168	PR-D3
169	PR-D5
170	PR-D7
171	IRQ4
172	IRQ6
173	IRQ9
174	IRQ11
175	IRQ14

**Table Section 4-7 Power Connector**

<b>Pin</b>	<b>Signal</b>
1	Not Defined
2	+19V
3	Ground

---

**Table Section 4-8 Hard Disk Drive Connector**

<b>Pin</b>	<b>Signal</b>
1	HDD Access LED
2	+5V
3	Chip Select 0
4	+5
5	Chip Select 1
6	+5V
7	Address 0
8	+5V
9	Addrss 2
10	+5V
11	Address 1
12	+5V
13	Diagnostic
14	Not Used
15	IRQ
16	Not Used
17	IO16I
18	IO Channel Ready
19	Cable Select
20	IO Write
21	I/O Read
22	Not Used
23	Data 0
24	Data 1
25	Data 15

---

**Table Section 4-9 Diskette Drive Connector**

<b>Pin</b>	<b>Signal</b>
1	SIDE
2	FDCNT
3	RDATA
4	No Connection
5	WPRT
6	Ground
7	Ground
8	No Connection
9	TRK0
10	Ground
11	WE
12	No Connection
13	WDATA
14	Ground
15	Ground
16	No Connection
17	STEP
18	Ground
19	DIR
20	No Connection
21	No Connection
22	MOTOR
23	DSKCHG
24	No Connection
25	DRVSEL
26	VCC
27	VCC
28	No Connection
29	INDEX
30	VCC

---

# Section 5 Index

## A

- AC adapter, 2-24
- Accessing auto setup, 2-9
- Active mode, 1-17, 2-28
- APM, 2-17
- Auto setup, 2-9
- Auto setup keys, 2-10
- Auto setup options, 2-11
- Automatic power saving, 2-28

## B

- Backlight, 2-13
- Battery charging time, 2-26
- Battery Pack, 1-4
- Battery power, 2-25
- BIOS update, 1-13
- Bridge battery, 1-4, 2-24
- BUU menu functions, 2-20
- BUU precautions, 2-17

## C

- Cable connections, 2-2
- CardSoft, 2-17
- CardView, 2-17
- Chip types, 1-11
- CMOS battery, 1-4
- CMOS switch, 2-6
- Connecting the AC adapter, 2-25
- Controls and switches, 2-3
- CRT connector pin assignments, A-3
- CRT port, 1-3

## D

- Diskette boot, 2-12
- Diskette connector assignments, A-11
- Diskette controller, serial interface, parallel interface, 1-14
- Downloading the BUU, 2-18
- DSTN, 1-3

## E

- Expansion port pin assignments, A-9

---

External keyboard connector pin assignments, A-2

## **F**

Flash ROM, 1-12, 2-17

Function keys, 2-5

## **H**

Hard disk drive connector pin assignments, A-10

Hardware failures, 2-8

Hardware overview, 1-2

Highlight, 2-13

## **I**

I/O connector descriptions, 2-2

Increasing system memory, 1-5

Interrupt level assignments, 1-16

## **K**

Keyboard, 1-4

Keyboard controller, 1-14

Keyboard lock hot key, 2-16

Keyboard lock hot keys, 2-12

Keyboard select switch, 2-4

Keyboard switch, 2-6

## **L**

LCD

    LCD types, 1-3

LCD backlighting, 1-3

LED descriptions, 2-4

Local device timers, 1-18

Local power management, 1-17

## **M**

Memory map, 1-6

Microprocessor, 1-1

## **N**

NEC utilities, 2-17

Normal charge, 2-26

## **O**

Operating controls, 2-3

Option part numbers, 3-4

---



## **P**

- Parallel interface enhanced capabilities port, 1-11
- Parallel port pin assignments, A-4
- Parameter descriptions, 2-12
  - comms, 2-12
  - drives, 2-12
  - keyboard, 2-12
  - power, 2-12
- PCMCIA controller, 1-14
- PCMCIA drivers/utilities, 1-14
- PCMCIA Slots, 1-4
- Pentium, 1-1
- Peripheral controller, 1-13
- Plug and play, 1-18
- PnP/VFD, 2-17
- Post error messages, 2-8
- Post errors, 2-8
- Power connector pin assignments, A-9
- Power management modes
  - active, 1-17
  - local standby, 1-17
  - suspend, 1-17
- Power management overview, 1-17
- Power management switch, 2-4
- Power management under AC, 2-13
- Power saving levels, 2-28
- Power sources, 2-24
- Power switch, 2-4
- Power-on self test (POST), 2-7

## **Q**

- Quick boot, 2-13
- Quick charge, 2-26

## **R**

- Rear panel connectors, 1-2
  - Recharging the battery pack, 2-26
  - Remove a password, 2-16
  - Replacing the battery pack, 2-26
  - Reset switch, 2-4
  - Resume on modem ring, 2-13
  - Resume on time of day, 2-13
  - ROM BIOS, 1-12
-

## **S**

- Saving battery power, 2-27
- Security options, 2-15
- Serial interface, 1-11
- Serial port connector pin assignments, A-3
- Shipping configurations, 1-1
- Smart power switch, 2-7
- Suspend mode, 1-17, 2-26, 2-28
- Suspend warning tone, 2-13
- System board, 1-3
- System board connectors, A-1
- System logic, 1-12
- System memory, 1-5
- System parameters, 2-7, 2-9
- System password, 2-12, 2-15
- System setup, 2-1
- System suspend mode, 2-13
- System video, 1-7

## **T**

- TFT, 1-3
- Time/date, 2-14
- Typematic rate, 2-12

## **U**

- Unpacking, 2-1
- Using auto setup, 2-14
- Using the update utility, 2-18

## **V**

- Versa 2000 I/O address map, 1-15
- Versa 2000 parts list, 3-1
- Versa 2000 system specifications, 1-19
- VersaGlide, 1-5
- VGA controller, 1-13
- Video controller architecture, 1-13
- Video mode
  - 640x480 DSTN, simultaneous CRT, 1-9
  - 640x480 TFT, simultaneous CRT, 1-9
  - CRT only, 1-7
- Video RAM, 1-7

---