HP OmniBook Sojourn

User's Guide

Notice

This manual and any examples contained herein are provided “as is” and are subject to change without notice. Hewlett-Packard Company makes no warranty of any kind with regard to this manual, including, but not limited to, the implied warranties of merchantability and fitness for a particular purpose. Hewlett-Packard Co. shall not be liable for any errors or for incidental or consequential damages in connection with the furnishing, performance, or use of this manual or the examples herein.

Consumer transactions in Australia and the United Kingdom: The above disclaimers and limitations shall not apply to Consumer transactions in Australia and the United Kingdom and shall not affect the statutory rights of Consumers.

© Copyright Hewlett-Packard Company 1998. All rights reserved. Reproduction, adaptation, or translation of this manual is prohibited without prior written permission of Hewlett-Packard Company, except as allowed under the copyright laws.

The programs that control this product are copyrighted and all rights are reserved. Reproduction, adaptation, or translation of those programs without prior written permission of Hewlett-Packard Co. is also prohibited.

Portions of the programs that control this product may also be copyrighted by Microsoft Corporation, ESS Technology Inc., Phoenix Technologies, Ltd., Neo Magic, Inc., and American Megatrends, Inc. (ForMIDiag). See the individual programs for additional copyright notices.

Microsoft, MS, MS-DOS, and Windows are registered trademarks of Microsoft Corporation. Pentium and the Intel Inside logo are U.S. registered trademarks and MMX is a U.S. trademark of Intel Corporation. Sound Blaster Pro is a registered trademark of Creative Labs, Inc. a subsidiary of Creative Technology, Ltd.

For warranty information, see the *Support and Service* booklet.

Hewlett-Packard Company
Mobile Computing Division
19310 Pruneridge Ave.
Cupertino, CA 95014

HP Software Product License Agreement

Your HP OmniBook PC contains factory-installed software programs. Please read the Software License Agreement before proceeding.

Carefully read this License Agreement before proceeding to operate this equipment. Rights in the software are offered only on the condition that the customer agrees to all terms and conditions of the License Agreement. Proceeding to operate the equipment indicates your acceptance of these terms and conditions. If you do not agree with the terms of the License Agreement, you must now either remove the software from your hard disk drive and destroy the master diskettes, or return the complete computer and software for a full refund.

Proceeding with configuration signifies your acceptance of the License Terms.

Unless otherwise stated below, this HP Software Product License Agreement shall govern the use of all software that is provided to you, the customer, as part of the HP computer product. It shall supersede any non-HP software license terms that may be found online, or in any documentation or other materials contained in the computer product packaging.

Note: Operating System Software by Microsoft is licensed to you under the Microsoft End User License Agreement (EULA) contained in the Microsoft documentation.

The following License Terms govern the use of the software:

Use. Customer may use the software on any one computer. Customer may not network the software or otherwise use it on more than one computer. Customer may not reverse assemble or decompile the software unless authorized by law.

Copies and Adaptations. Customer may make copies or adaptations of the software (a) for archival purposes or (b) when copying or adaptation is an essential step in the use of the software with a computer so long as the copies and adaptations are used in no other manner.

Ownership. Customer agrees that he/she does not have any title or ownership of the software, other than ownership of the physical media. Customer acknowledges and agrees that the software is copyrighted and protected under the copyright laws. Customer acknowledges and agrees that the software may have been developed by a third party software supplier named in the copyright notices included with the software, who shall be authorized to hold the Customer responsible for any copyright infringement or violation of this Agreement.

Product Recovery CD-ROM. If your computer was shipped with a product recovery CD-ROM: (i) The product recovery CD-ROM and/or support utility software may only be used for restoring the hard disk of the HP computer with which the product recovery CD-ROM was originally provided. (ii) The use of any operating system

software by Microsoft contained in any such product recovery CD-ROM shall be governed by the Microsoft End User License Agreement (EULA).

Transfer of Rights in Software. Customer may transfer rights in the software to a third party only as part of the transfer of all rights and only if Customer obtains the prior agreement of the third party to be bound by the terms of this License Agreement. Upon such a transfer, Customer agrees that his/her rights in the software are terminated and that he/she will either destroy his/her copies and adaptations or deliver them to the third party.

Sublicensing and Distribution. Customer may not lease, sublicense the software or distribute copies or adaptations of the software to the public in physical media or by telecommunication without the prior written consent of Hewlett-Packard.

Termination. Hewlett-Packard may terminate this software license for failure to comply with any of these terms provided Hewlett-Packard has requested Customer to cure the failure and Customer has failed to do so within thirty (30) days of such notice.

Updates And Upgrades. Customer agrees that the software does not include updates and upgrades which may be available from Hewlett-Packard under a separate support agreement.

Export Clause. Customer agrees not to export or re-export the software or any copy or adaptation in violation of the U.S. Export Administration regulations or other applicable regulation.

U.S. Government Restricted Rights. Use, duplication, or disclosure by the U.S. Government is subject to restrictions as set forth in subparagraph (c) (1) (ii) of the Rights in Technical Data and Computer Software clause in DFARS 252.227-7013. Hewlett-Packard Company, 3000 Hanover Street, Palo Alto, CA 94304 U.S.A. Rights for non-DOD U.S. Government Departments and Agencies are as set forth in FAR 52.227-19(c) (1,2).

Edition History

Edition 1 March 1998



This manual is printed on recycled paper.

Contents

1. Introducing the OmniBook	1-1
Taking Inventory	1-3
What is included in the OmniBook box	1-4
OmniBook features	1-5
To get more information	1-7
Getting Started	1-8
To charge the OmniBook battery for the first time	1-9
To run Windows Setup	1-10
Configuring the OmniBook with Setup	1-11
To run the Setup utility	1-12
Configuring the OmniBook with PowerPanel	1-16
To display the PowerPanel toolbar	1-16
To close PowerPanel	1-16
To select a power management profile	1-17
2. Getting Comfortable	2-1
Starting and Stopping the OmniBook	2-3
To turn the OmniBook on and off	2-4
To select a power mode	2-5
To select options for stopping the OmniBook	2-6
To configure the power button	2-7
To configure Suspend mode	2-7
To configure the lid switch	2-8
To reset the OmniBook	2-9
Using the OmniBook Touch Pad	2-10
To control the pointer	2-10
To drag objects	2-10
To ensure proper touch pad performance	2-11
Using the OmniBook Display	2-12
To adjust the display	2-12
To extend the life of the display	2-12
Using the OmniBook Keyboard	2-13
To use the Fn hot keys	2-13
To use the Windows 95 keys	2-14
To use the backslash key on the British Keyboard	2-15

Checking the status of the OmniBook	2-16
To read the status lights	2-16
Protecting the OmniBook	2-17
To set a password	2-17
To change or delete a password	2-18
To attach a security cable	2-18
To install McAfee VirusScan	2-19
3. Managing Battery Power	3-1
Monitoring Battery Power	3-3
To check the battery status	3-4
To respond to a low-battery warning	3-4
To recharge the internal battery	3-4
To connect a battery slice	3-5
To remove a battery slice	3-6
To charge a battery slice	3-7
To check the status of the battery slice	3-9
Conserving Battery Power	3-10
To save battery power	3-11
To set automatic time-outs	3-12
4. Making Connections	4-1
Connecting the Multimedia Expansion Slice	4-3
To connect the expansion slice	4-4
To remove the expansion slice	4-5
Using Floppy Disk and CD-ROM Drives	4-6
To insert and eject a floppy disk	4-6
To insert or remove a CD	4-7
To use the CD-ROM drive safely	4-8
To open the CD-ROM drive manually	4-8
Connecting External Devices	4-9
To connect an external monitor	4-10
To enable the built-in or external display	4-11
To connect a parallel device	4-12
To connect a serial device	4-13
To connect an external keyboard	4-14
To connect a mouse	4-15
To connect Universal Serial Bus devices	4-16
To insert a PC Card	4-18
To remove a PC Card	4-19
List of tested PC Cards	4-20
To connect audio devices	4-20
To make an infrared connection	4-22

5. Using the Recovery CD	5-1
Installing Drivers	5-3
Contents of the Recovery CD	5-4
To install an operating system	5-5
Recovering OmniBook Files	5-6
To install Windows 95 (factory-installation)	5-6
To update the OmniBook BIOS	5-7
6. Troubleshooting	6-1
Solving Problems	6-3
Accessory Problems	6-3
Audio Problems	6-4
Display Problems	6-4
Floppy Disk Drive Problems	6-5
Hard Disk Drive Problems	6-5
Keyboard, Mouse, and Touch Pad Problems	6-6
Infrared Problems	6-7
Memory Problems	6-8
PC Card (PCMCIA) Problems	6-8
Performance Problems	6-9
Power and Battery Problems	6-10
Printing Problems	6-12
Serial and Parallel Port Problems	6-13
Startup Problems	6-14
Testing the Operation	6-15
To create a diagnostic floppy disk	6-15
To run the diagnostic test	6-16
7. Specifications and Regulatory Information	7-1
Hardware Specifications	7-3
Software System Resources	7-4
Safety Information	7-6
Regulatory Information	7-9
U.S.A.	7-9
Canada	7-10
Japan	7-10
European Declaration of Conformity	7-11

Introducing the OmniBook

Introducing the OmniBook

Congratulations! Your OmniBook sets a new standard in personal computing. Smaller, thinner, and lighter for executives and managers on the move—only 3.2 pounds and 0.71 inches thick—the OmniBook provides

- ◆ State-of-the-art mobile computing technologies for reduced size and weight.
- ◆ Intel 233 MHz mobile Pentium processors with MMX technology for higher performance and lower power consumption.
- ◆ Large yet ultra-thin display.
- ◆ Elegant, durable design.

Using these and other advanced technologies, the OmniBook Sojourn offers exceptional portability plus the leading PC performance that executives and managers expect from Hewlett-Packard.

Taking Inventory

The HP OmniBook Sojourn represents a new category of HP notebook computers featuring the latest mobile technologies available.

This section describes

- ◆ What's included in the OmniBook package.
- ◆ A description of OmniBook features.
- ◆ How to attach ac power and charge the battery.
- ◆ How to set up Windows 95.
- ◆ How to configure the OmniBook with the Setup utility.

What is included in the OmniBook box

- HP OmniBook Sojourn.
- Multimedia expansion slice (also sold separately, HP F1431A).
- AC adapter (also sold separately, HP F1434A) and power cord.
- This OmniBook *User's Guide*.
- *Introducing Microsoft Windows 95* manual, Certificate of Authenticity, and *Microsoft Windows 95 Companion CD*.
- *Support and Service* booklet.
- *Quick Start* sheet.
- OmniBook *Recovery CD*. Includes Windows 95 recovery and operating system drivers.

OmniBook features

The following illustrations point out the main external features of the computer.

OmniBook—Front View

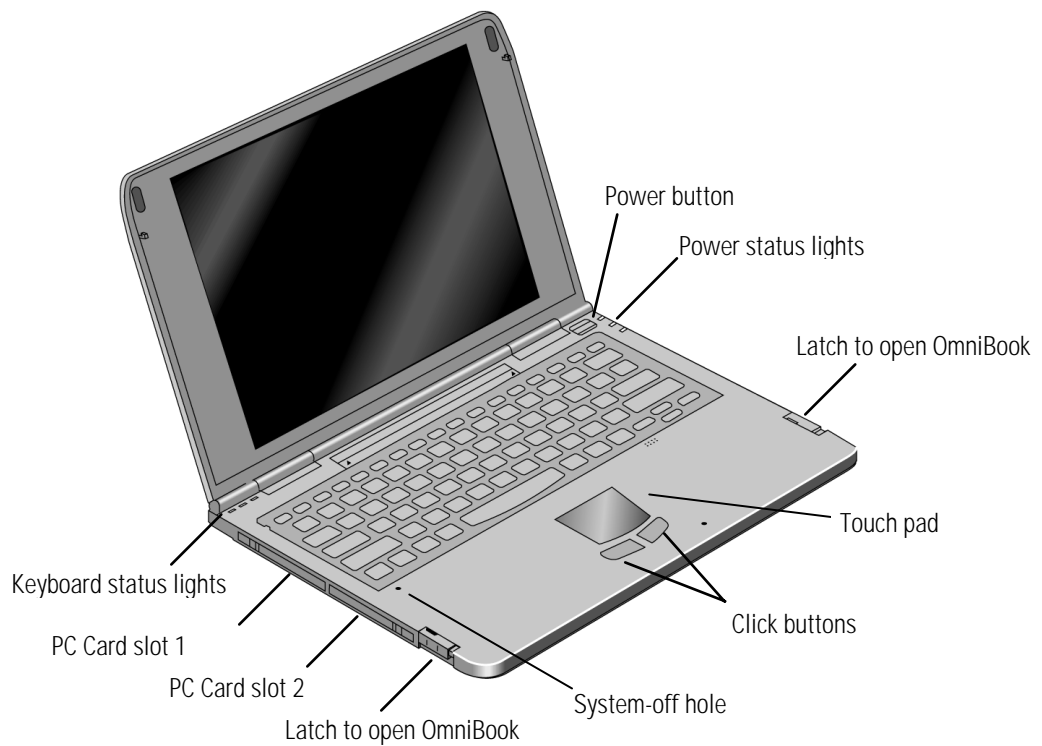

Introducing the OmniBook
Taking Inventory

OmniBook—Back View

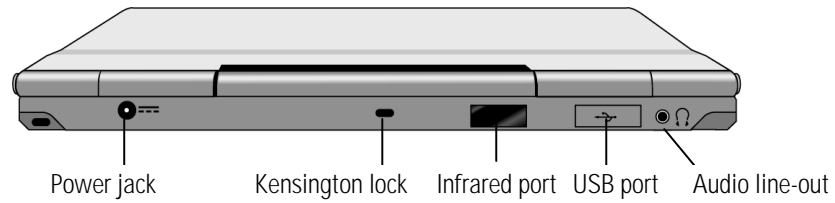

Multimedia Expansion Slice—Back View

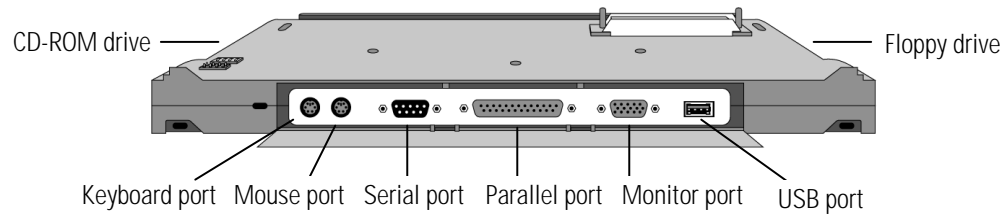

OmniBook Audio Features—(OmniBook and multimedia expansion slice)

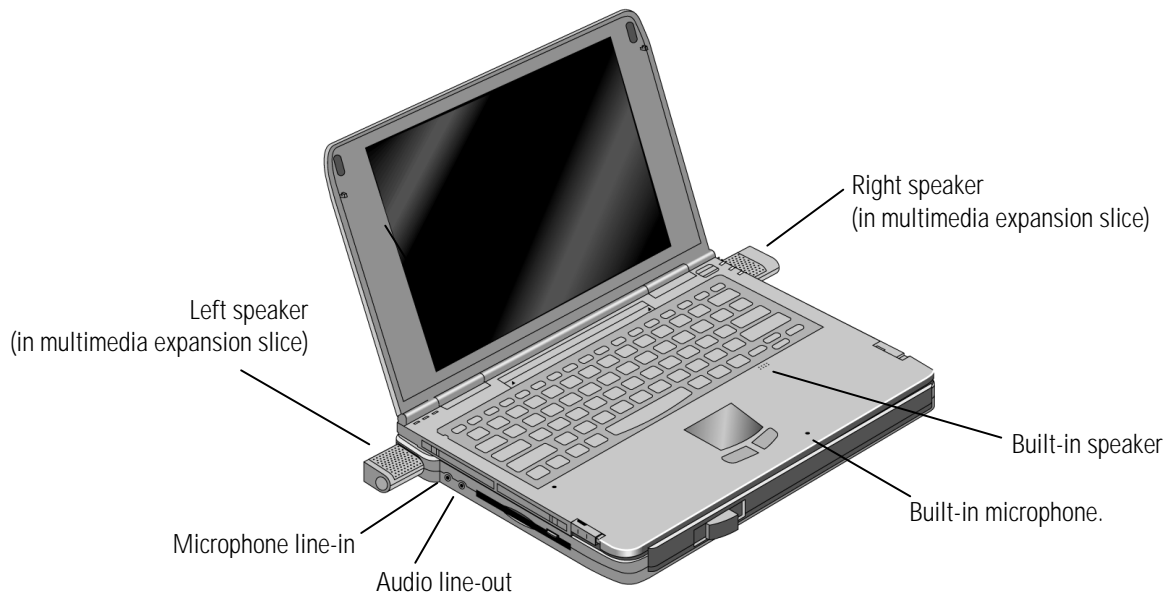

To get more information

This *User's Guide* and the *Quick Start* sheet describe the hardware of your OmniBook as well as the basics of how to use and operate it. Retain them for future reference.

We also provide the following additional sources of documentation.

Source	Location
<i>The Introducing Microsoft Windows 95</i> manual	This is shipped with your OmniBook and contains information about using the standard features of Windows 95.
HP website	http://www.hp.com/omnibook (http://www2.hp.com/omnibook , European mirror)
<i>Support and Service</i> booklet	See the <i>Support and Service</i> booklet for telephone numbers.

Getting Started

The OmniBook has Windows 95 factory-installed on the hard disk drive. When your OmniBook starts up the first time, it takes you through a series of setup screens, including setting up the operating system.

This section describes how to

- ◆ Charge the OmniBook battery for the first time.
- ◆ Run Windows Setup.

To charge the OmniBook battery for the first time

The first time you plug in the adapter, let the OmniBook's internal battery charge completely. Fully charging the internal battery takes 2 to 3 hours if the OmniBook is off (8 to 10 hours if the OmniBook is on).

The ac adapter is normally warm to the touch whenever it is plugged into an ac outlet. The OmniBook is normally warm while it's charging. Don't charge it in a briefcase or other confined space as this may cause the battery to overheat.

CAUTION

Use only the HP adapter model F1434A with this product. Using any other ac adapter could damage the OmniBook and void your warranty.

1. Connect the power cord to the ac adapter, then plug the power cord into an ac outlet.
2. Connect the ac adapter to the OmniBook's ac adapter port, as shown. The battery starts charging automatically and the battery charging light turns orange.

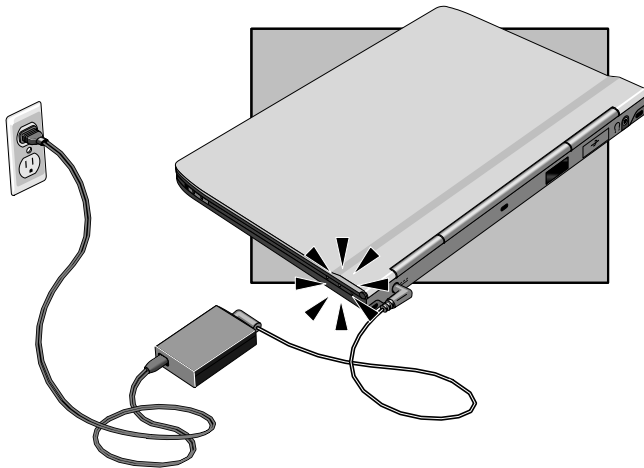

To run Windows Setup

This procedure describes how to set up the OmniBook with the factory-installed Windows operating system.

1. Connect the OmniBook to ac power as described in the previous procedure.
2. Open the OmniBook and press the power button.

The Windows 95 Setup program starts automatically.

3. Follow the instructions as they appear on the screen.
 - During setup, you will be prompted to select the correct Keyboard Layout. Check your keyboard. Select United States 101 if you have a # symbol above the 3 key. Select British if you have a £ (pound Sterling) symbol above the 3 key.
 - During setup, you will be prompted to accept the License Agreement and enter the Product ID (printed on the Certificate of Authenticity on the Microsoft *Introducing Windows 95* book). You are also prompted to set up a user account and Windows password. You can either set up the account, or press ESC to skip this step. You can set a Windows password at any time via Control Panel, Password.

Configuring the OmniBook with Setup

The Setup utility is a menu-driven utility that enables you to make changes to the system configuration and tailor the operation of your OmniBook to your individual work needs.

The settings made in the Setup utility generally control the hardware and consequently have a fundamental effect on how the OmniBook operates.

This section describes the Setup utility menus and options in detail.

To run the Setup utility

1. Close all applications, then shut down Windows and reboot the OmniBook.
2. When you see the HP logo, press F2 to enter the BIOS Setup utility.
3. The touch pad or mouse is not active in the Setup utility. Press the RIGHT and LEFT arrow keys to move among menus. Press the DOWN and UP arrow keys to move among parameters in a menu. Press F4 or F5 to change a setting. Press ENTER to open a submenu. See the tables below for more information.
4. After you select the options you want, press F10 to exit the Setup utility.

Main Menu	Description	Default
System Time	Sets the time using 24-hour format.	00:00:00
System Date	Sets the date.	00/00/0000
Legacy Diskette A	Sets the floppy drive type.	1.44/1.25 MB
Primary Master	Sets parameters of drive attached to primary IDE adapter (hard disk drive).	2.1 GB HDD
Secondary Master	Sets parameters of drive attached to secondary IDE adapter (CD-ROM).	CD-ROM
Boot Options	Selects the order the system searches drives for a boot disk.	A: then C:
OS Legacy Mode Support	Select "Yes" if using a plug-and-play operating system.	Yes
Numlock	Selects power-on state for Numlock.	Off
Memory Cache	Sets the CPU memory cache.	Enabled
System Memory	Shows the system memory size.	640 KB
Extended Memory	Shows the extended memory size.	64512 KB
CPU Type	Shows the CPU type.	Pentium with MMX
CPU Speed	Shows the CPU speed.	233 MHz

Advanced Menu	Description	Default
I/O Device Configuration		
Serial Port A	Configures serial port A	Auto
Serial Port B (Infrared Port)	Configures infrared port.	Disabled
Mode	Set mode (Normal, IrDA, ASK-IR, or FIR) for infrared port (Serial Port B).	Normal
Parallel Port	Configures parallel port.	Auto
Mode	Sets mode (Output Only, bidirectional, ECP, or EPP) for parallel port.	Bidirectional
Floppy Disk Controller	Configures floppy disk controller.	Enabled
Large Disk Access Mode	UNIX, Novell Netware, or other operating systems, select "Other."	DOS
Local Bus IDE adapter	Enables local bus IDE adapter.	Both

Security Menu	Description	Default
User Password Is	Shows if a user password is set.	Clear
Supervisor Password Is	Shows if a supervisor password is set.	Clear
Set User Password	Press ENTER to set, change, or clear the password and save all Setup changes. (Up to 8 alphanumeric keys).	
Set Supervisor Password	Press ENTER to set, change, or clear the password and save changes	
Password on Boot	Required a password to boot.	Disabled
Diskette Access	Restricts floppy drive use to supervisor. Requires setting Supervisor password and enabling Password On Boot.	User
Fixed Disk Boot Sector	Write protects boot sector on hard disk to protect against viruses.	Normal

Introducing the OmniBook
 Configuring the OmniBook with Setup

Power Saving	Description	Default
Switch Button	Sets the Switch Button to Suspend/Resume or to On/Off.	Suspend/Resume
Power Management	Disables time-outs, selects a combination of time-outs, or allows customized time-outs.	Maximum Power Saving
Idle Mode	Turns Idle mode on and off. Idle mode slows down the CPU during brief periods when the system is not busy.	On
Standby Time-out	Sets the period of inactivity after which the computer goes to Standby power mode.	2 minutes
Suspend Mode	Sets the type of Suspend mode to Suspend-to-RAM or Save-to-Disk.	Save To Disk
Auto Suspend Time-out	Sets the period of inactivity after which the computer goes to Suspend mode.	5 minutes
Hard Disk Time-out	Sets the period of hard disk inactivity after which the hard disk stops spinning.	30 seconds
Video Time-out	Turns off the computer screen after the set period of inactivity.	4 minutes
Resume on Modem Ring	When enabled, sets the system to resume when receiving a ring signal.	Off
Resume on Time	When enabled, sets the system to resume at Resume Time specified.	Off
Resume Time	Specify a time when the system is to resume (24-hour time format).	00:00:00
Resume Date	Specify a date when the system is to resume (mm/dd/yyyy format).	00/00/0000

Exit Menu	Description	Default
Exit Saving Changes	Saves Setup changes, exits, and reboots.	none
Exit Discarding Changes	Discards Setup changes since last save, exits, and reboots.	none
Load Setup Defaults	Restores all default settings, and stays in Setup.	none
Discard Changes	Discards Setup changes since last save, and stays in Setup.	none
Save Changes	Saves Setup changes, and stays in Setup.	none

Configuring the OmniBook with PowerPanel

The OmniBook provides additional power management options through the Phoenix ® PowerPanel™ utility. PowerPanel is a 32-bit application that runs under Windows 95.

Important

If PowerPanel is running in Windows, the PowerPanel settings override those in the BIOS Setup utility.

To display the PowerPanel toolbar



Atom icon

By default, PowerPanel is preinstalled and displayed on the OmniBook.

- To display the PowerPanel toolbar, left-click the atom icon displayed at the right end of the Windows taskbar.

There are five buttons on the PowerPanel:

- AC Profile (default power management settings when on ac power)
- Maximum Performance (power management settings for high performance)
- Maximum Battery Life (default power management settings when on battery power; for extending battery life)
- Suspend to RAM (saves current work session and suspends activity to save power)
- Save to Disk (saves data and current work session, and shuts down to save power)

To close PowerPanel

- Right-click on the PowerPanel toolbar, then click Exit. The current power management settings of the system remain activated.

To select a power management profile

PowerPanel provides a group of predefined profiles that you can select according to the type of work you are doing on the OmniBook. The following table describes the PowerPanel profiles.

For complete documentation about PowerPanel features, download the Phoenix *User's Guide* from: <http://www.phoenix.com/notebook/ppanel.html> or see the PowerPanel online Help (right-click on the PowerPanel toolbar, then click PowerPanel Help Topics).

Default Power Management Profiles
AC. Turns off video and hard disk drive after a predetermined period of time, but doesn't initiate automatic Suspend to RAM or Save to Disk modes.
Maximum Performance. Sets power saving features to give you the best system performance while still conserving power.
Maximum Battery Life. Sets power saving features to give you the maximum battery life and good performance.

Getting Comfortable

Getting Comfortable

This chapter introduces the OmniBook and helps you get familiar with basic operation including how to

- ◆ Start and stop the OmniBook.
- ◆ Use the OmniBook touch pad.
- ◆ Adjust the OmniBook display.
- ◆ Use the OmniBook keyboard.
- ◆ Check the status of the OmniBook.
- ◆ Protect the OmniBook.

Note

As with any PC, you should make a regular habit of backing up the information from your hard disk drive onto external media. Furthermore, if your HP OmniBook Sojourn should require service, all the information on your hard drive will be lost because computer repair involves a *computer exchange*. You will *not* receive your original computer or hard drive after service. The returned unit *will* have the operating system loaded on the hard drive and be ready for you to reload your applications and data files.

Starting and Stopping the OmniBook

You can always start and stop your OmniBook using the power button. However, at certain times, you may want to use other methods for starting and stopping your OmniBook—depending on power considerations, types of active connections, and start-up time.

This section describes how to

- ◆ Turn the OmniBook on and off.
- ◆ Select various power modes.
- ◆ Select an option for stopping the OmniBook.
- ◆ Configure power modes.
- ◆ Reset the OmniBook.

To turn the OmniBook on and off

The easiest way to start and stop the OmniBook is to use the power button. *However, to save significant power and extend battery life, it is best to stop the OmniBook by shutting it down (Start menu, Shut Down).*

CAUTION

Do not hold down the power button for more than 4 seconds. This can cause the display to “white out.” If this should happen, press the power button again or press the system-off button to reset the computer. If this white-out is not corrected within 15 minutes or so, it can damage the display.

1. Slide the latches on the sides of the OmniBook forward and lift up the lid.

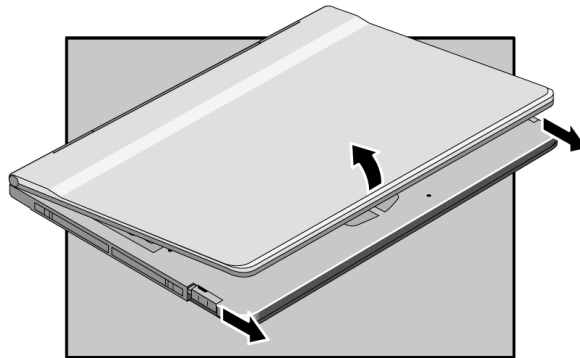

2. Press the power button to turn on the OmniBook.

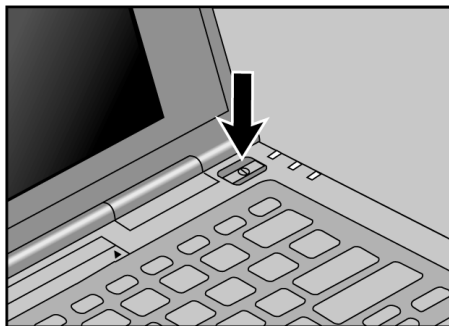

3. To *turn off* the OmniBook and save significant power, select Shut Down from the Start menu.

To *suspend* the OmniBook, you can press the power button. (This is the default setting, which can be changed in the Setup utility.) This darkens your display but maintains your work session. This does not save as much power.

To select a power mode

This section describes the OmniBook power modes and provides information to help you choose the mode that best fits your needs.

Power mode	Description
Standby	Turns off the display. Maintains network connections. Restarts quickly.
Suspend	Turns off the display. Saves current session in RAM. Saves significant power. Loses network connections. * Restarts quickly.
Save to Disk	Saves maximum power. Saves current session on hard disk. Loses network connections. *
Off	Saves maximum power. Loses network connections. Resets everything at startup. Starts a new session at startup.

* Windows 95 can restart the network connections when you turn on the OmniBook. For a different operating system, you may have to reboot the OmniBook or restart the operating system to restore them.

If the ac adapter is connected, the OmniBook battery continues to charge in any mode.

To select options for stopping the OmniBook

You can stop the OmniBook several ways, as shown below. Some methods allow you to continue your work where you left off. Others reboot the computer. These power modes are described below.

To stop in this mode...	Do this...	To turn on again...
Standby	Allow the time-out to expire without activity.	Press any key or move the pointer.
Suspend	Press the "Suspend to RAM" icon on the PowerPanel toolbar. Note: The power button as well as Start menu, Suspend can be redefined as Suspend-to-RAM. (Default meaning is Save-to-Disk). See page 2-7.	Press the power button, which resumes the session immediately
Save to Disk	Press the "Save To Disk" icon on the PowerPanel toolbar. -or- Press the power button while the OmniBook is on. (This is the default, but the power button can be reconfigured.) -or- From the Start menu, click Suspend. (This is the default, but can be reconfigured.)	Press the power button, which reboots the computer and restores the session.
Off	From the Start menu, click Shut Down. Unsaved data will be lost. The computer will reboot when you turn it back on. -or- Note: The power button can be configured to Off. See page 2-7.	Press the power button, which reboots the computer and starts a new session.

To configure the power button

By default, the power button suspends the OmniBook. You can configure the power button to either suspend the OmniBook or shut it down completely.

“Suspend” in this configuration can mean either “Suspend to RAM” or “Save to Disk” (default). See the next topic to define “Suspend”.

1. From the Start menu, shut down, then restart the OmniBook.
2. When you see the HP logo, press F2 to enter the BIOS Setup utility.
Active keys are described along the bottom of the screen. (The pointing devices do not work in BIOS Setup.) Help information for the highlighted item appears in the right-hand sidebar in the display.
3. From the Power Saving menu, select Switch Button.
4. Select Suspend/Resume or On/Off.
5. Press F10 to save and exit.

To configure Suspend mode

You can configure Suspend mode to either suspend the OmniBook (“Suspend to RAM”) or save the state of the computer to disk and then shut down (“Save to Disk”). *By default, the OmniBook Saves to Disk.*

For a complete explanation of power modes and help in choosing the best mode for your needs, see page 2-5.

1. From the Start menu, shut down, then restart the OmniBook.
2. When you see the HP logo, press F2 to enter the BIOS Setup utility.
Active keys are described along the bottom of the screen. (The pointing devices do not work in BIOS Setup.) Help information for the highlighted item appears in the right-hand sidebar in the display.
3. From the Power Saving menu, select Suspend Mode.
4. Select Suspend or Save To Disk.
5. Press F10 to save and exit.

To configure the lid switch

You can configure the behavior of the OmniBook when closing the computer lid.

1. If the Notebook icon is not displayed on the Windows taskbar, from the Start menu, click Programs, HP Utility, Lid and Display Switch.
2. Double-click the Notebook icon on the Windows taskbar.
3. Choose one of the following options:
 - Auto (default). Automatically detects if the OmniBook is connected to a multimedia expansion slice. If connected, closing the lid turns off the display. If not connected, closing the lid suspends the OmniBook (*Suspend to RAM*).
 - Enable. Closing the lid suspends the OmniBook (*Suspend to RAM*).
 - Disable. Closing the lid turns off the display.
4. Click OK to exit.

To reset the OmniBook

If Windows or the OmniBook stops responding, you can reset the OmniBook and restart Windows.

1. Insert a straightened paper clip into the System Off button near the Fn key, as shown.
2. After the OmniBook shuts down, press the power button to turn it back on.

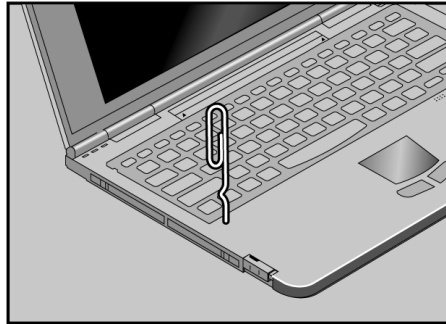

Using the OmniBook Touch Pad

The touch pad is a touch-sensitive pointing device located in front of the keyboard. The two click buttons are located in front of the touch pad.

The touch pad controls the motion and speed of the pointer on the screen. The click buttons work like those on a standard mouse—what the buttons do depends on the software being used.

This section describes how to

- ◆ Control the pointer.
- ◆ Drag objects.
- ◆ Ensure proper touch pad performance.

To control the pointer

The touch pad controls the motion of the pointer on the screen by detecting the motion of your finger.

1. To move the cursor, move your finger or thumb across the touch pad in the direction you want the pointer to move.
2. To select an item, click the left button.

--OR--

Tap on the surface of the touch pad. *To double-click, tap twice.*

To drag objects

1. First move the pointer over the item.
2. Tap twice and leave your finger pressed on the touch pad.
3. Drag your finger on the touch pad to move to the new location.
4. Pick up your finger to drop the object.

To ensure proper touch pad performance

Use the following guidelines to ensure proper touch pad operation:

- Use the pad of your finger and not just your finger tip.
- Tap the touch pad surface lightly. Do not use excessive force.

CAUTION

Do not use a pen or other sharp object on the touch pad. This may damage the touch pad surface.

Note

The touch pad has settings to adjust its sensitivity, speed, and how it uses the right and left click buttons. To adjust these settings, double-click My Computer, Control Panel, Mouse. Or, double-click on the touchpad icon (“AlpsPoint95”) on the taskbar.

Using the OmniBook Display

The OmniBook display is a 12.1-inch SVGA active-matrix (TFT) display (800 × 600 ×64K colors). It supports PCI local bus video, 128-bit graphics controller with 2-MB video RAM, and Zoomed Video in the back slot (enabled by default). This section describes

- ◆ How to adjust the display brightness.
- ◆ How to extend the life of the display.

To adjust the display

Some models of the OmniBook include these brightness controls:

- Press Fn+F8 to decrease the brightness.
- Press Fn+F9 to increase the brightness.

To maximize your battery operating time, set the brightness to the lowest comfortable setting, so that the internal light uses less power.

To extend the life of the display

Observe the following guidelines to maximize the life of the backlight in the OmniBook display.

- Set the brightness to the lowest comfortable setting (Fn+F8).
- When working at your desk, connect an external monitor and turn off the internal display.
- Avoid using a screen saver or other software that prevents the OmniBook from changing to Suspend or Standby mode after a time-out period.
- Do not disable Suspend or Standby time-outs.

Using the OmniBook Keyboard

WARNING

Improper use of keyboards and other input devices has been associated with ergonomic injury. For information about reducing your risk, see the “Working in Comfort” instructions provided with your OmniBook, or at our website, <http://www.hp.com/ergo>.

This section describes the special features of the OmniBook keyboard including

- ◆ Fn hot keys.
- ◆ Windows 95 keys.
- ◆ Extra key for British keyboard.

To use the Fn hot keys

Labeled F1 through F12, these keys provide shortcut key sequences for various system controls. The OmniBook keyboard shows the Fn hot keys labeled in orange.

This hot key sequence	Does this
Fn + F8	Decreases the display's brightness.
Fn + F9	Increases the display's brightness.
Fn + F10	Toggles the speaker on and off (Mute key).
Fn + NL/SL	Toggles Scroll Lock on and off.
Fn + LEFT Arrow	Moves to Home.
Fn + RIGHT Arrow	Moves to End.
Fn + UP Arrow	Moves up one page.
Fn + Down Arrow	Moves down one page.





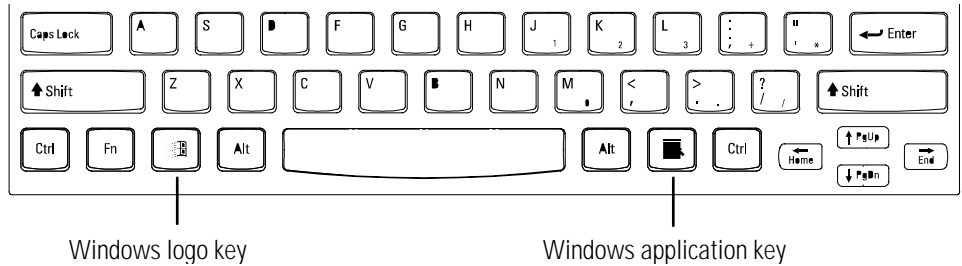

To use the Windows 95 keys

The keyboard has two keys dedicated to Windows 95.



Windows Logo Key

When you press another key while holding the Windows logo key, the OmniBook provides the following functions:

This key sequence	Does this
	Performs the same function as when you click on the Start button in Windows.
 + Tab	Makes applications active in the order they are indicated on the task bar.
 + E	Activates the Explorer.
 + F	Looks for a file or folder (Same as with "Start" "Find" "Files or Folders").
 + M	Minimizes (iconizes) all windows.
Shift +  + M	Restores a minimized window to its original size.
 + R	Specifies a file name and run (same as with "Start" "Run").

Windows Application Key

The Windows Application key displays a menu, just as if you clicked on the right mouse button. The menu displayed depends on the current application and the item selected.

To use the backslash key on the British Keyboard

On the British keyboard of OmniBook Sojourn, there is one key that does not appear in its usual place. This is the backslash (\) key with a shifted vertical bar (|). This key, sometimes called the “102 key” (the one hundred and second key), typically appears to the left of the spacebar, but here appears on the F2 key.







- To access the 102 key (\), press Fn+F2.
- To access the shifted character (|), press Fn+Shift+F2.

Checking the status of the OmniBook

The OmniBook contains three status lights to the right of the keyboard and three status lights to the upper left of the keyboard.

- The lights to the right show power, battery, and drive activity.
- The lights to the left show Caps lock, Num lock, and Scroll lock.

To read the status lights

Indicator	Meaning
	Power Green when power is on. Orange when OmniBook is suspended (to RAM).
	Battery power Green when battery is completely charged. Orange when battery is charging.
	Drive activity The OmniBook is accessing the built-in hard disk drive.
	Caps lock Caps Lock is on.
	Num lock Num Lock is on.
	Scroll lock Scroll Lock is on.

Protecting the OmniBook

Your OmniBook provides several ways for you to identify and protect your computer. This section describes how to

- Set up password protection.
- Clear a password.
- Attach a security cable.
- Use McAfee VirusScan.

To set a password

You must first set a Supervisor password before you can set a User password. If password protection is set, then you will be prompted to enter a password whenever you reset or turn on the computer (depending on your setting).

To set or change password protection, use the Setup utility .

1. Reset the computer and press F2 during the boot process to enter the Setup utility. Active keys are described along the bottom of the screen. (The touch pad or mouse does not work in Setup.)
2. Select the Security menu.
3. Select Set Supervisor Password, then press ENTER.
4. Type the new password, then press ENTER. *The password can contain up to eight alphanumeric characters, and it is not case-sensitive.*
5. Type the password again to confirm.
6. If desired, select Set User Password to enter a User Password.
7. Press F10 to save and exit Setup.

CAUTION

Be sure you record your password in a safe place. If you forget your password, you will need to return your OmniBook PC to Hewlett-Packard for repair. The repair entails loss of the hard drive's data. You will also need your proof-of-purchase. Call Hewlett-Packard at the number in the *Support and Service* booklet.

To change or delete a password

If you delete a Supervisor Password, the User Password is deleted automatically.

1. Reset the computer and press F2 during the boot process to enter the Setup utility. Active keys are described along the bottom of the screen. (The touch pad does not work in the Setup utility.)
2. Select the Security menu.
3. Select Set User Password (or Set Supervisor Password), then press ENTER.
4. Type the current password, then press ENTER.
5. Press ENTER at the Enter New Password prompt.
6. Press ENTER at the Confirm New Password prompt.
7. Press Continue to save changes.

To attach a security cable

Your OmniBook has a built-in connector that allows you to secure the OmniBook with a cable. The Kensington MicroSaver lock system works with these connectors and is available at many computer stores.

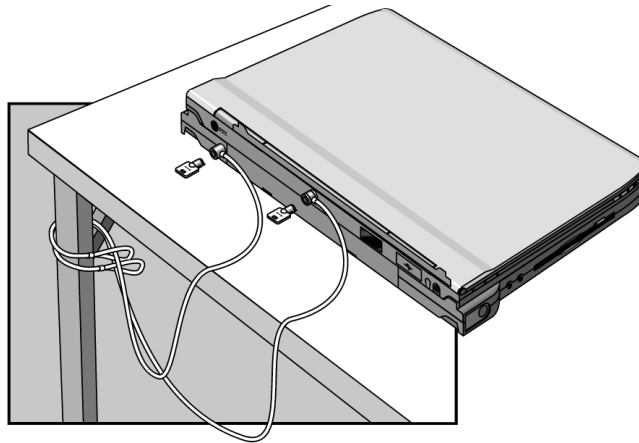

To install McAfee VirusScan

The OmniBook comes equipped with McAfee VirusScan, which currently detects over 13,500 viruses. As an HP OmniBook owner, you are entitled to 90 days free support from McAfee and one free upgrade to VirusScan. For details, see the Readme file under Start, Programs, McAfee VirusScan.

Before you can use VirusScan, you need to install it.

1. From the Start menu, click Programs, McAfee VirusScan, Setup.
2. Follow the instructions as they appear on the screen.

Once installed, you can get detailed online instructions under VirusScan Help.

Managing Battery Power

Managing Battery Power

The OmniBook conserves power by using Advanced Power Management (APM), software that controls battery charging and power drain.

The OmniBook provides several safeguards so you won't be surprised by a dead-battery condition, including the following:

- ◆ The OmniBook automatically saves to disk and turns off when the battery charge gets too low—your session will continue after you start recharging the battery or attach a charged battery slice, and restart the computer.
- ◆ Data on any of the drives is preserved when the battery is low—unless the battery runs down completely while writing data to the drive, or if the battery in a PC RAM card is also low.
- ◆ Windows 95 should display a warning for a low-battery condition.

Monitoring Battery Power

The primary source of power for the OmniBook is its rechargeable internal battery. typical battery life is 1.5 to 2.0 hours, but varies with type of usage.

You can use the ac adapter to recharge the battery or to run on ac power to preserve the battery. You can also use the enhanced battery slice to approximately quadruple your battery session.

Important

Running external connections is a power-intensive operation that significantly shortens the length of a battery session. Whenever possible, connect the ac adapter when using external connections.

This section describes how to

- ◆ Check the battery and respond to a low-battery warning.
- ◆ Recharge the battery.
- ◆ Connect and remove a battery slice.
- ◆ Charge a battery slice and check its status.

To check the battery status

- From the Windows taskbar, place the pointer over the battery indicator at the right end of the taskbar. The approximate battery charge is displayed in a pop-up window.
- For additional power information, double-click the battery power indicator to open the Battery Meter window.

To respond to a low-battery warning

When battery power is critically low, the OmniBook displays a low-battery warning. After approximately 3 minutes, the OmniBook automatically saves to disk to preserve your current session. You won't be able to restart until you restore power by one of the following actions:

- Plug in the ac adapter; or
- Connect a charged battery slice to the OmniBook.

To recharge the internal battery

Fully charging the internal battery takes 2 to 3 hours if the OmniBook is off (8 to 10 hours if the OmniBook is on).

CAUTION

The ac adapter is normally warm to the touch whenever it is plugged into an ac outlet. The OmniBook is normally warm while it's charging. Don't charge it in a briefcase or other confined space as this may cause the battery to overheat.

1. Connect the power cord to the ac adapter, then plug the power cord into an ac outlet.
2. Connect the cord from the ac adapter to the ac adapter port on the OmniBook. The battery indicator light turns orange when the battery is charging.

To connect a battery slice

The enhanced battery slice approximately quadruples the battery life. You can attach a battery slice to either the OmniBook or to the multimedia expansion slice.

1. From the Start menu, shut down the OmniBook.
2. Close the display and turn over the OmniBook.
3. Slide open the battery connector cover on the bottom of the computer (or the expansion slice).

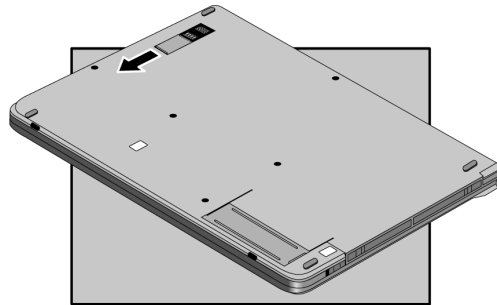

4. Align the catch on the battery with the slot on the rear of OmniBook (or expansion slice) and slide into place.
5. Push the front part of the computer until it clicks. Avoid excessive pressure.
6. Charge the battery slice before using it the first time, as it may not be fully charged. (See "To charge a battery slice," following.)

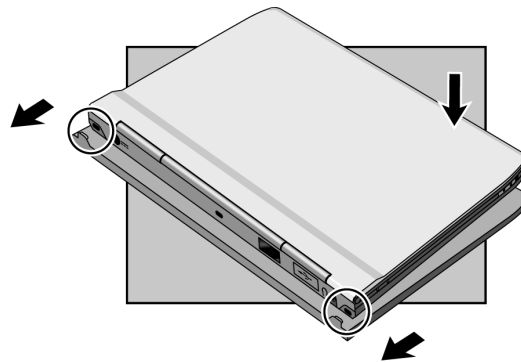

To remove a battery slice

1. From the Start menu, shut down the OmniBook.
2. Close the display.
3. Slide the two latches on the battery slice as shown.
4. Remove the computer from the battery slice.

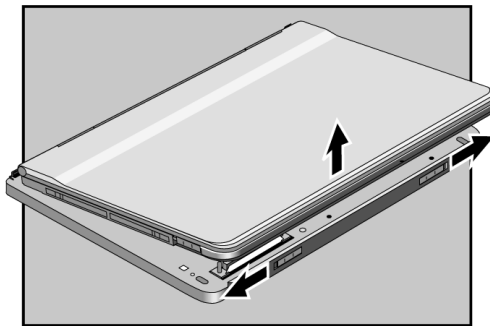

5. Close the battery connector door on the bottom of the OmniBook (or on the bottom of the multimedia expansion slice).

To charge a battery slice

CAUTION

Use only the HP F1434A adapter. Using another adapter could damage your OmniBook and void the warranty.

There are different methods for recharging the battery slice depending on whether it is connected to the OmniBook or not.

Recharging the battery slice when connected to the OmniBook

This will recharge the computer's internal battery *first*, up to 10 hours to the charging time (depending on its current charge level and whether the computer is on or not).

1. Connect the power cord to the ac adapter and plug the power cord to an outlet.
2. Connect the ac adapter to the OmniBook.
3. You can recharge the battery slice while using the computer. However, it will charge faster if you are not using the OmniBook.

See the chart on the following page for a list of battery-slice charging times.

Important

Do not connect the ac adapter to the battery slice when the slice is connected to the OmniBook or to the multimedia expansion slice. No charging will result!

Recharging the battery slice when *not* connected to the OmniBook

1. Connect the power cord to the ac adapter and plug the power cord to an outlet.
2. Connect the ac adapter directly to the battery slice, as shown.

Managing Battery Power
Monitoring Battery Power

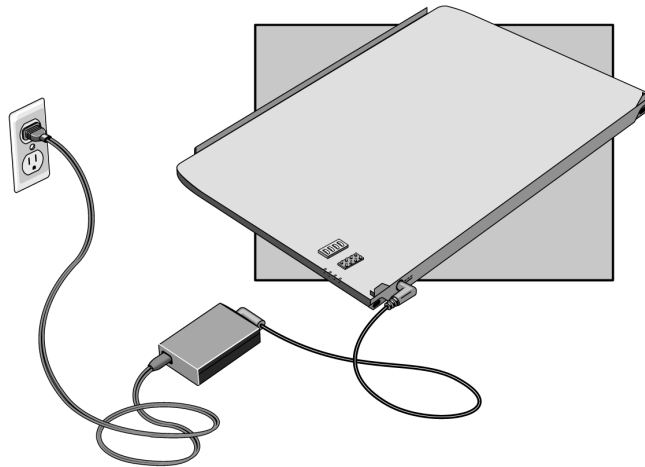

Charging Method: AC connected to	Battery-Slice Charging Time
OmniBook, turned off	6 to 9 hours
OmniBook, turned on	24 to 27 hours
Battery Slice	6 to 9 hours

About Battery Charge / Discharge Order

If you have a battery slice connected to the OmniBook, the OmniBook's internal battery charges first and discharges last.

To check the status of the battery slice

Press the battery button to view the approximate charge of the battery slice. The number of lights indicates the charge level. Four lights means the battery is fully charged. The charge light is orange when the battery slice is charging; green when the battery is fully charged.

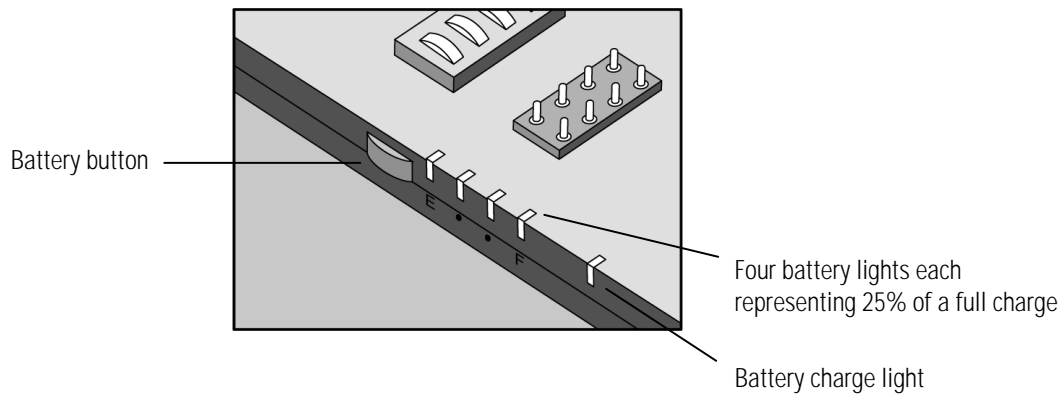

Conserving Battery Power

The OmniBook uses Advanced Power Management (APM) to conserve battery power. You can take steps to optimize your battery operating time.

This section describes how to

- ◆ Save battery power.
- ◆ Specify the automatic time-out settings.

See page 7-7 for safety information about handling and storing batteries

To save battery power

Follow these suggestions to conserve battery power.

- Plug in the ac adapter, especially while using the floppy disk drive, the CD-ROM drive, or any external connections.
- Put the OmniBook in Suspend mode whenever you are not using it for a short while.
- Turn the OmniBook off (or save to disk) whenever you will not be using it for several hours or more.
- Turn the brightness of the display down to the lowest comfortable level. This reduces the backlight power, *which can increase the battery operating time as well as the overall life of the display.*
- Set the automatic time-out settings to emphasize saving power. (See the following topic.)
- If you work with an application that uses the serial port or a PC Card, exit the application when you are done using it.
- If you have an I/O PC Card—that is, a PC Card having an external connection, such as a modem or network card—remove it when you are not using it. Some I/O cards use significant power, even while they're inactive.

To set automatic time-outs

PowerPanel and the Setup utility include settings for automatic time-outs at specified periods of inactivity. *PowerPanel settings override Setup settings when PowerPanel is running.*

In PowerPanel, power-use profiles define time-out settings and other power controls. You can create a power-use profile or edit an existing one.

To use PowerPanel to set time-outs:

1. To create or edit a PowerPanel profile, first right-click on an empty space in the PowerPanel toolbar. This displays the Shortcut menu.
2. Click Customize, Buttons tab, Create Profile.

To create a new profile, define its power management settings, then click File, Save to name it.

To edit an existing profile, click File, Open, select a profile, edit its settings, then click File, Save (or File, Save As to save it as a different profile). *Note that some settings cannot be edited.*

Refer to PowerPanel's online Help (right-click on the empty space of the PowerPanel, then click on PowerPanel Help Topics) or the PowerPanel *User's Guide* at www.phoenix.com.notebook/ppanel.html for complete instructions.

To use the Setup utility to set time-outs:

1. Reboot the OmniBook, then press F2 to enter the Setup utility. Active keys are described along the bottom of the screen. (The touch pad or mouse does not work in Setup.)
2. In the Power Saving menu, select Power Management and choose an option other than disabled. You have the following choices:
 - Maximum Power Savings: The time-out settings are defined for best power savings (relatively short time-outs).
 - Maximum Performance: The time-out settings are set for fast performance with some power conservation (relatively long time-outs).
 - Customized: You determine each setting for Standby Time-out, Suspend Time-out, Hard Disk Time-out, and Video Time-out.
3. Choose your Time-out settings. Press F10, then press ENTER to save your settings.

Making Connections

Making Connections

A multimedia expansion slice comes standard with this OmniBook notebook PC. You can also purchase an additional one using the HP part number F1431A. Your OmniBook is a powerful computer in its own right—but you can greatly expand its capabilities by connecting other devices with the multimedia expansion slice.

Important

Before you connect any device, check the documentation that came with the equipment to see if you need to make any settings or adjustments to the equipment before using it. This might include setting switches to configure the equipment so that it will operate properly with the OmniBook and the software you plan to use.

This chapter describes how to

- ◆ Connect, remove, and secure the multimedia expansion slice.
- ◆ Use the built-in floppy disk drive and CD-ROM drive in the multimedia expansion slice.
- ◆ Connect external devices to ports in the multimedia expansion slice.

Connecting the Multimedia Expansion Slice

With the OmniBook multimedia expansion slice, you can significantly increase the convenience of your OmniBook for desktop use. By making one connection—plugging your OmniBook into the expansion slice—you can get easy access to parallel and serial devices, external monitor, keyboard or mouse, USB devices, audio devices, and infrared connections.

This section describes how to

- ◆ Connect the expansion slice.
- ◆ Remove the expansion slice.

To connect the expansion slice

1. From the Start menu, shut down the OmniBook.
2. Close the display and turn over the OmniBook.
3. Slide open the two connector covers as shown. *Do not open the connector cover on the bottom of the computer except to connect to a multimedia expansion slice or a battery slice.*

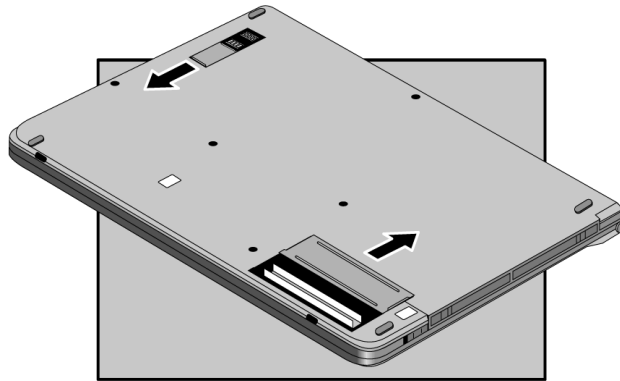

4. Align the catch of the expansion slice with the slots on the rear of the computer, then gently press down on the front of the OmniBook until it clicks into place.

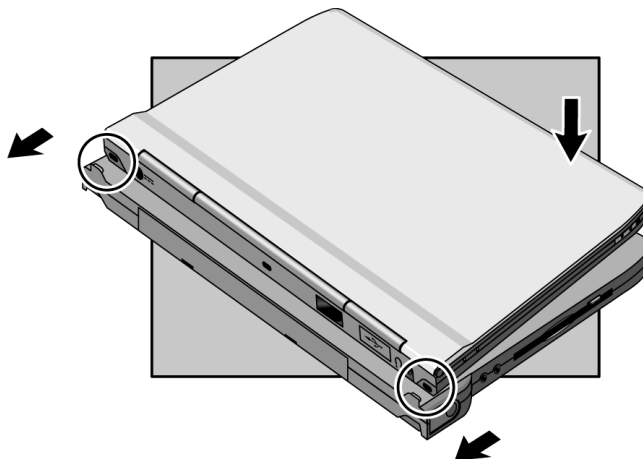

To remove the expansion slice

1. If necessary, remove any floppy disk or CD from the drives.
2. From the Start menu, shut down the OmniBook.
3. Close the display.
4. Slide the lever on the front of the expansion slice to the left as shown, then remove the slice.

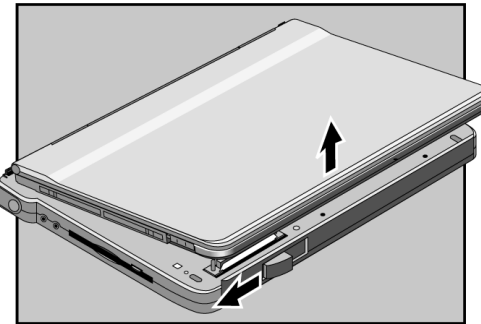

5. Close both of the connector doors on the bottom of the OmniBook.

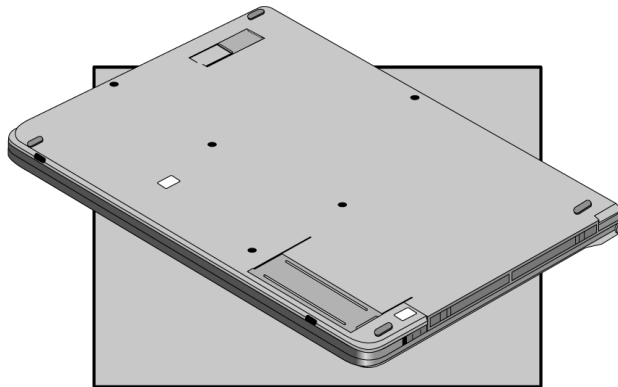

Using Floppy Disk and CD-ROM Drives

This section describes how to

- ◆ Insert and eject a floppy disk.
- ◆ Insert and remove a CD.
- ◆ Open the CD-ROM drive manually.

To insert and eject a floppy disk

CAUTION

Do not remove a floppy disk while the OmniBook is actively reading or writing data to the floppy disk. Otherwise, you could lose data or the OmniBook could stop responding.

1. Hold the disk with its face up, then slide it into the floppy disk drive in the multimedia expansion slice as shown.

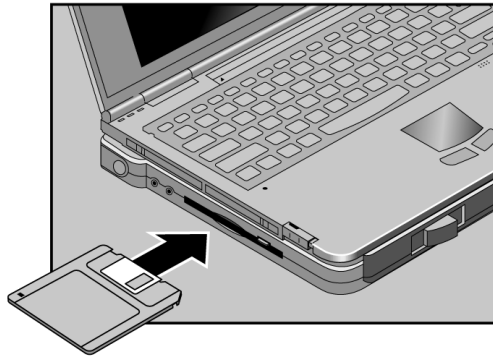

2. To remove the floppy disk, press the eject button.

To insert or remove a CD

CAUTION

Do not remove a CD while the OmniBook is actively reading data from the CD. Otherwise, the OmniBook could stop responding and you could lose data.

1. Turn on the computer power.
2. Press the open button in the center of the CD-ROM drive in the multimedia expansion slice.

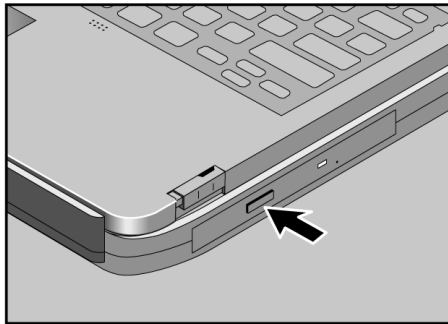

3. Place the CD into the drive and *gently press down to seat the CD on the spindle.*
--or--
Remove the CD.
4. Push the CD-ROM tray in until it clicks into place.

To use the CD-ROM drive safely

- If the unit requires service, contact an authorized HP service center—see the OmniBook *Support and Service* booklet.
- Do not attempt to make any adjustment to the unit.
- Avoid direct exposure to the laser beam.
- Be sure to fully seat the CD on the spindle.

To open the CD-ROM drive manually

If you lose power to the OmniBook, or if you have removed the OmniBook from the multimedia expansion slice, you can manually open the CD-ROM drive to remove a CD.

- Insert a straightened paper clip into the small hole, as shown.

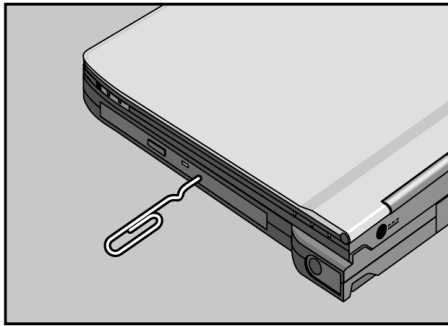

Connecting External Devices

Your OmniBook is a powerful computer in its own right—but you can greatly expand its capabilities by connecting other devices. This section describes how to

- ◆ Connect an external monitor and enable it.
- ◆ Connect a parallel device.
- ◆ Connect a serial device.
- ◆ Connect an external PS/2 keyboard or PS/2 mouse.
- ◆ Connect Universal Serial Bus (USB) devices.
- ◆ Insert and eject PC Cards.
- ◆ Connect audio devices.
- ◆ Make an infrared connection.

To connect an external monitor

1. From the Start menu, shut down (or suspend) the OmniBook.
2. Plug the connector of the external monitor into the external monitor connector on the rear of the multimedia expansion slice and tighten both screws to secure the connector

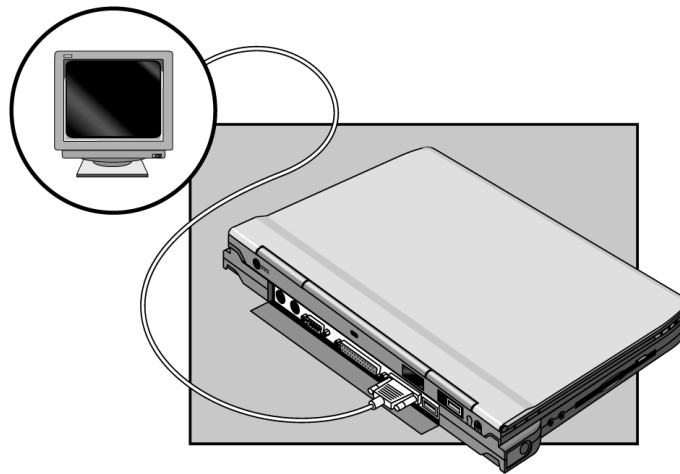

3. Connect the monitor to a power source and turn it on.
4. Press the power button to turn on the OmniBook.
By default, the OmniBook detects the external monitor and turns off the internal display.

Note

If the external monitor has a different resolution from the internal display, adjust the display properties (My Computer, Control Panel, Display, Settings).

To enable the built-in or external display

For a Temporary Change

- Press SHIFT+ALT+BACKSPACE to cycle through the display options (built-in, external, both).

For a Permanent Change

Change the settings in the Lid and Display Utility .

1. From the Start menu, click Programs, HP Utility, Lid and Display Utility.

–or–

Click the notebook-computer icon on the Windows taskbar.

2. Click LCD for the built-in display, CRT for the external display, or BOTH. (Click Show Dialog for the full options of the Lid and Display Utility.) Click EXIT when done.

To connect a parallel device

The parallel port uses a standard 25-pin connector, most commonly used for connecting a printer.

1. From the Start menu, shut down (or suspend) the OmniBook.
2. Plug the connector of the printer cable into the parallel port connector on the rear side of the Multimedia expansion slice. Tighten both the screws to secure the connection. *To connect the cable to the printer, see the manual included with the printer.*
3. Connect the printer to a power source and turn it on.
4. Press the power button to turn on the OmniBook.

You can set up the parallel port on the “I/O Device Configuration” screen of the Setup utility.

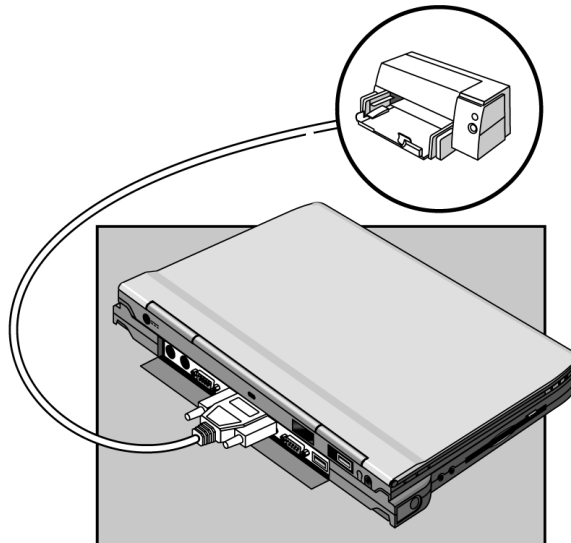

Important

Turn on the printer power before turning on the OmniBook. Before disconnecting the printer, turn off the printer power and then turn off the OmniBook.

To connect a serial device

The OmniBook's serial port uses a standard 9-pin serial connector. Serial connections typically are to external modems. You can make such connections using standard serial cables and adapters available at computer dealers and electronic supply stores.

1. From the Start menu, shut down (or suspend) the OmniBook.
2. Connect the serial cable to the serial port on the rear of the multimedia expansion slice.

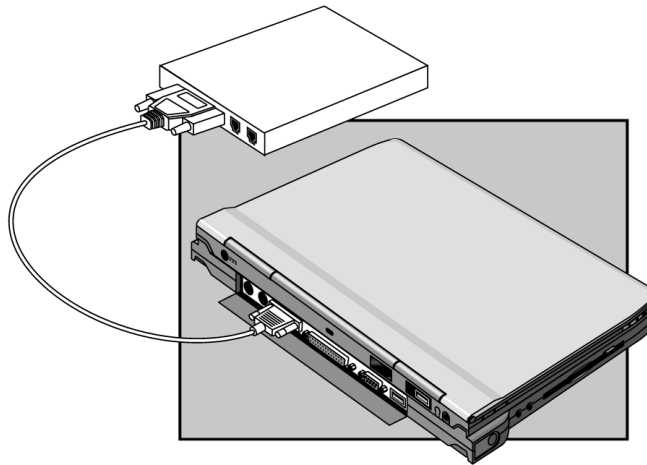

To connect an external keyboard

The 6-pin PS/2 port allows you to attach an external keyboard to the OmniBook.

1. From the Start menu, shut down (or suspend) the OmniBook.
2. Plug the connector of the external keyboard or numeric keypad into the keyboard connector on the rear of the multimedia expansion slice.
3. Press the power button to turn on the OmniBook.

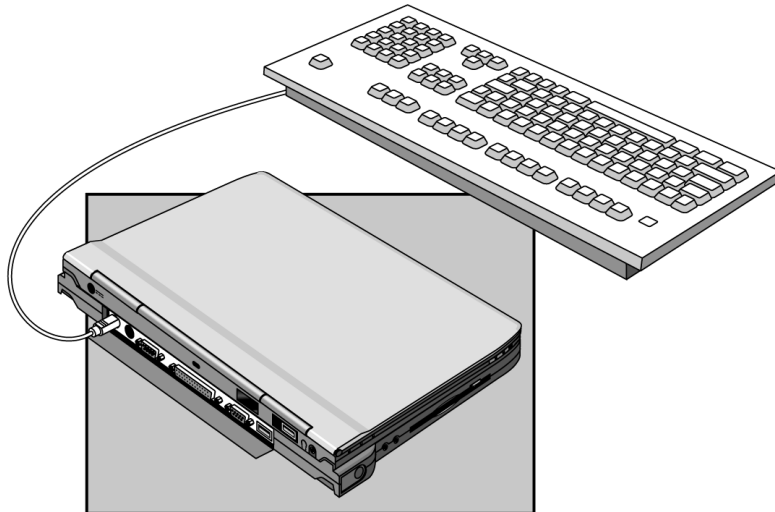

To connect a mouse

You can connect a mouse having a PS/2 interface to the mouse connector on the multimedia expansion slice. When a mouse is connected, the touch pad is disabled. A PS/2 keyboard and mouse with Y-adapter is not supported.

1. From the Start menu, shut down (or suspend) the OmniBook.
2. Plug the connector of the mouse into the mouse connector on the rear of the multimedia expansion slice.
3. Press the power button to turn on the OmniBook.

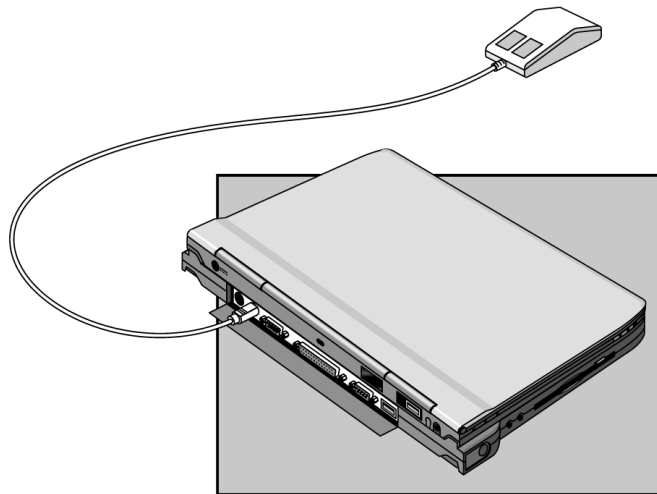

To connect Universal Serial Bus devices

The Universal Serial Bus (USB) provides a bi-directional serial interface for adding peripheral devices such as game controllers, serial and parallel ports, and scanners to a single bus. The OmniBook and the multimedia expansion slice both have a USB connector. If the multimedia expansion slice is connected to the computer, two USB connectors can be used simultaneously.

1. From the Start menu, shut down (or suspend) the OmniBook. (Some USB devices do not require this step if they can be “hot docked”.)
2. On the OmniBook, open the rubber cover of the USB port.

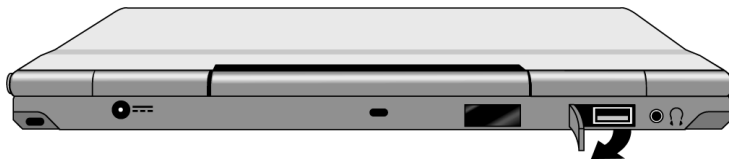

3. Connect the USB equipment to the USB port on the computer or on the multimedia expansion slice.
4. Press the power button to turn on the OmniBook. Windows 95 automatically recognizes the USB device. Some USB devices can be connected to the OmniBook in series with other USB devices—a “daisy-chain” connection.

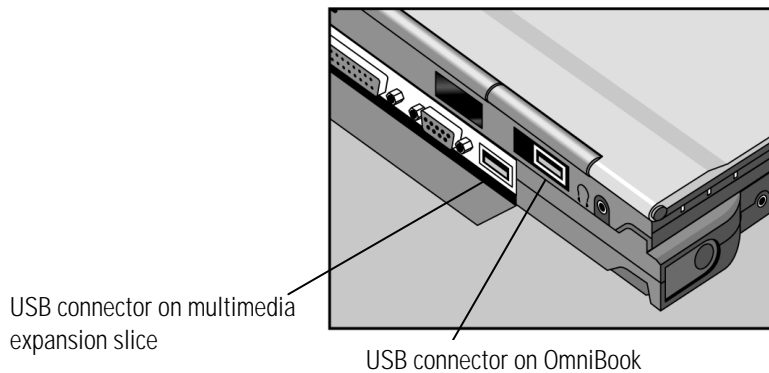

Note

If you have problems making the USB connection, contact the vendor of the peripheral device, as well as Hewlett-Packard, for the latest versions of the USB drivers. The USB technology is dynamic and continues to develop.

To insert a PC Card

The OmniBook PC Card slots are available for storing data and expanding the communication capabilities of the OmniBook. Both slots are CardBus slots. Only the rear slot supports zoomed video.

1. Hold the PC Card with its face up and its connector holes toward the card slot.
2. Slide the PC Card into the slot until it is flush with the OmniBook.

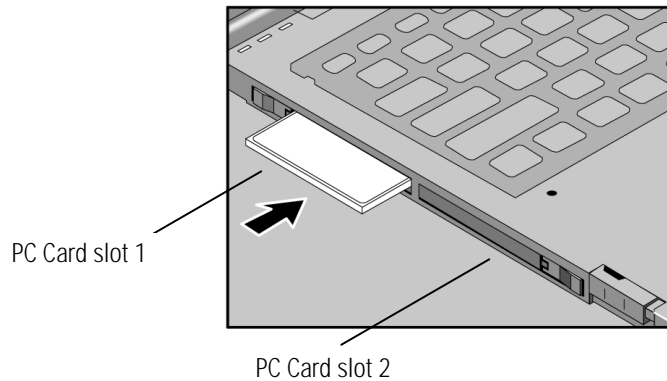

3. If the PC Card requires a cable, connect it. For details, see the documentation included with the PC Card.

To remove a PC Card

CAUTION

Do not insert or remove a PC Card while the OmniBook is actively reading or writing data. Otherwise, you could lose data or the OmniBook could stop responding.

1. Click the PC Card indicator in the taskbar, then click Stop.

This protects your data and avoids unexpected problems. You can restart the card by removing it, then inserting again.

2. Flip out the eject button, then push it in.

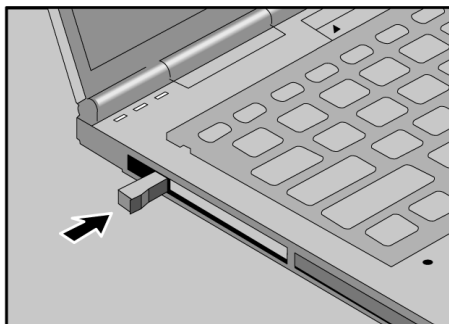
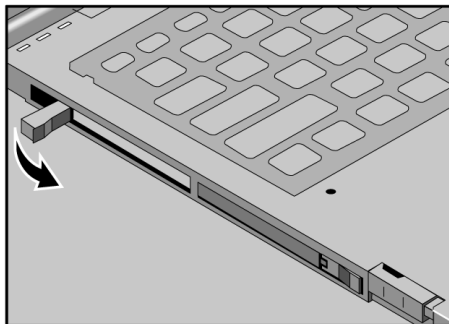

List of tested PC Cards

At the time of this printing, the following cards have been tested for use with the OmniBook using Windows 95 (OSR2). For the latest information about compatible cards, visit our website at <http://www.hp.com/omnibook> and check the Approved Solutions. Or contact Hewlett-Packard (see the *Support and Service* booklet).

Manufacturer	Card Description
3COM	XJ-1336 PC Card Modem
3COM	3C589D PC Card 10Mbps LAN
3COM	3C575 PC Card 10/100 CardBus LAN
Xircom	CEM56 10/100 Combo 56K PC Card Modem + 10/100 LAN
Xircom	CE3 PC Card 10/100 Ethernet LAN
Xircom	CM56 56K PC Card Modem

To connect audio devices

You can plug in a stereo input source, (such as a CD player), an external microphone, external speakers, or headphones. In addition, there is a built-in microphone near the touch pad (to the right and below).

1. From the Start menu, shut down (or suspend) the OmniBook.
2. Attach the audio cable to the corresponding audio port on the computer or on the expansion slice (see picture below).
3. Push in and then pull out the speakers built into the sides of the multimedia expansion slice.
4. Press the power button to turn on the OmniBook.

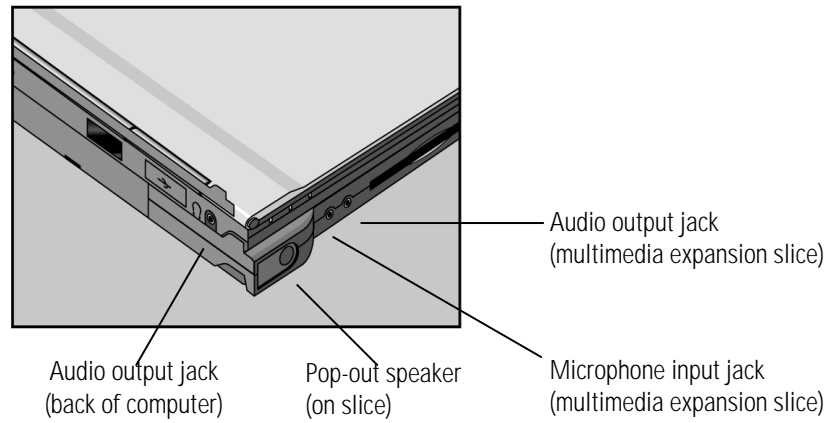

Note

When you plug a device into the microphone jack, the built-in microphone automatically turns off. When you plug a device into the audio output jack, the built-in speakers automatically turn off.

To make an infrared connection

The infrared (IR) port is on the back panel of the OmniBook. It provides wireless, serial communication between the OmniBook and other IR-equipped devices such as printers and other OmniBooks.

Note

By default, the IR port is *not enabled*. You must install the appropriate IR drivers and enable IR in the Setup utility (Advanced menu, I/O Device Configuration, Serial Port B).



Infrared port

- Line up the OmniBook's IR port and the other IR port in as straight a line as possible. The two ports should be no more than 1 meter (3 feet) apart, with no obstructions in between

Using the Recovery CD

Using the Recovery CD

This chapter has instructions for installing a new operating system and software drivers or recovering the original OmniBook software. You can install or recover a factory-installed version of the Windows 95 operating system, drivers for other operating systems, and OmniBook files.

This section describes how to

- ◆ Install drivers and other operating systems.
- ◆ Recovering OmniBook files, including the factory-installed operating system.

Installing Drivers

If you have formatted the OmniBook's hard disk drive and loaded your company's disk image, the *Recovery CD* provides OmniBook-specific software and device drivers that you can add to your disk image.

This section describes how to

- ◆ Find individual audio, video, infrared, and PC Card drivers for the Windows 95 operating system. Each driver has a Readme file with instructions.
- ◆ Install an operating system (other than the Windows 95 factory installation).

Contents of the Recovery CD

Directory	Contains
README.TXT text file	Instructions for using the <i>Recovery</i> CD.
RECOVER\	
ENC	Encrypted Microsoft Windows 95 recovery files. (Usable only in conjunction with the <i>Support Utilities</i> disk.)
BOOTDISK	For creating your own copy of a boot disk (like the <i>Support Utility</i> disk).
FILE.CHK	Checksum list (also for FAT32).
OMNIBOOK\	
DRIVERS	Use this to manually install individual audio, video, infrared, and PC-Card (PCMCIA) drivers for Windows 95. Look for the specific driver for the specific version of your operating system. Each driver has a README file with instructions.
HPUTILS	Use this to copy the OmniBook Notes and Support files to the \OmniBook directory on your hard drive.

The following sections tell you how to set up and start a recovery installation. Refer to the README text file on the *Recovery* CD for step-by-step instructions.

To install an operating system

You provide the software to install an alternate operating system. The *Recovery CD* provides the OmniBook-specific drivers to configure your custom system. The drivers for Windows 95 are located

- On the *Recovery CD* under \OmniBook\Drivers.
- On the OmniBook hard drive under C:\OmniBook\Drivers.
- On the OmniBook website at <http://www.hp.com/omnibook>. This website contains the latest updates of software drivers.

Different versions of an operating system require different drivers, so make sure to select the appropriate driver.

Before you start, gather the equipment you'll need—the OmniBook, its ac adapter, the expansion slice, and the *Recovery CD*.

1. Connect the multimedia slice to the OmniBook (see page 4-4 for instructions).
2. Connect the ac adapter to the OmniBook.
3. Install the operating system.
4. Install the OmniBook-specific drivers according to the instructions in the README files that accompany the drivers.

Recovering OmniBook Files

This section describes how to

- ◆ Install the Windows 95 operating system (factory-installation).
- ◆ Update the OmniBook BIOS.

To install Windows 95 (factory-installation)

The following procedure describes how to install the Windows 95 operating system that came with your OmniBook. These steps will format the hard disk drive. Back up any files you would like to save before installing Windows 95.

To install the Windows 95 operating system, you'll need the *Recovery CD*.

1. Connect the OmniBook to the multimedia expansion slice.
2. Connect the ac adapter to the OmniBook.
3. Insert the *Recovery CD* in the CD-ROM drive.
4. Make sure the CD-ROM drive is first in the boot order in the Setup utility, Main menu, Boot Options.
5. Press CTRL+ALT+DEL to reboot the OmniBook. The MS-DOS Startup menu appears.
6. Choose "Recover Windows 95 from OmniBook Recovery CD."
7. Follow the setup instructions on the screen. The process continues automatically.

The recovery process can take up to an hour. Do not interrupt the recovery process or unplug the ac adapter until recovery is completed.

To update the OmniBook BIOS

Hewlett-Packard may update the BIOS to enhance the capabilities of the OmniBook. Updates will be available from HP Electronic Support Services.

Caution

Because a BIOS update replaces the previous version, it is very important you follow these instructions exactly. Otherwise, you may damage the OmniBook.

1. From the Start menu, shut down the OmniBook.
2. Connect the ac adapter to the OmniBook.
3. Remove any PC Cards.
4. Insert the BIOS Update disk in the floppy disk drive.
5. Press the power button.
6. When prompted, press C. This starts a process that takes approximately 1 minute.
7. When prompted, press the system-off button.

Do not interrupt the update process.

———— Troubleshooting

Troubleshooting

If you run into problems with your OmniBook, you can use the suggestions in this chapter for getting back on track.

If you have questions that this manual doesn't answer, you can

- Look at the online Help for Windows and other applications.
- Find technical information about the OmniBook on the Internet—visit the Support website at <http://www.hp.com/omnibook>.
- See other books about Windows, MS-DOS, and other applications. Check your local library or bookstore.
- Contact your dealer, or contact Hewlett-Packard—see the OmniBook *Support and Service* booklet or OmniBook Support in the online OmniBook Library.

To get information about system resources (interrupts, addresses, and memory), see “Software System Resources” on page 7-4.

Note

If your OmniBook needs repair, first back up your data onto external media, if possible. The repair of an HP OmniBook Sojourn involves a *computer exchange*, so the information on your hard drive will be lost. You will *not* receive the return of your original computer or its hard disk drive. The returned unit *will* have the operating system loaded on the hard drive and be ready for you to re-load your applications and data files. See the *Support and Service* booklet for more information.

Solving Problems

If your OmniBook has a problem, find the symptom below that matches your situation. Try the suggestions one at a time.

Accessory Problems

If a multimedia expansion slice port isn't working

- Check the connection between the device and the expansion slice.
- Check the connection between the OmniBook and the expansion slice.

If you can't boot from a CD in the CD-ROM drive

- Press ESC during the boot process, then choose the CD-ROM drive as the boot device (a temporary change). See the next suggestion for a permanent change.
- Check the boot order in the Setup utility (Boot Options, Main menu). The CD-ROM must come first.
- Make sure you are using the CD-ROM drive in the multimedia expansion slice. You cannot boot from an external CD-ROM drive.
- Check that the CD is bootable.
- Reset the OmniBook.

Audio Problems

The HP OmniBook Sojourn is the state of the art in small size and portability. This limits certain audio components, which limits the audio fidelity of the system.

If sounds aren't audible

- Check that the volume is not muted.
- Check the settings in the Setup utility—from the System Devices menu, check that Audio is enabled.
- Check for sound resource conflicts in the Setup utility or Windows Device Manager.

If sound doesn't record

- Check the playback or recording sound levels.
- Check settings in the Setup utility—from the System Devices menu, check that Audio is enabled.

Display Problems

If the OmniBook is on, but the screen is blank

- Press the space bar to see if the computer is in Standby mode.
- Press Fn+F9 to increase the display brightness.

If the screen is difficult to read

- Check whether the display resolution is set to its default setting, 800 × 600 (SVGA). Check this in Start, Settings, Control Panel, Display, Settings.

Floppy Disk Drive Problems

If the OmniBook's floppy disk drive doesn't work

- Check the connection between the OmniBook and the expansion slice.
- Check settings in the Setup utility —from the System Devices menu, check FDD Controller.
- If trying to boot from a floppy disk, check the boot order in the Setup utility (Boot menu). The default setting is A: then C:.

Hard Disk Drive Problems

If the OmniBook's hard disk drive doesn't spin

- Check the power source.

If the hard disk drive makes buzzing or whining noise

- Back up the drive immediately.

If files are corrupted

- First, back up the files on the drive.
- Run a virus scan program.
- Boot to DOS and run CHKDSK to look for problems, then run CHKDSK /f to fix.
- Run Scandisk surface scan to check the platter.
- Use the Recovery CD to recover files that are corrupted.

Keyboard, Mouse, and Touch Pad Problems

If the pointer is difficult to control

- Adjust the pointer settings using Control Panel, Mouse.

If the touch pad doesn't work

- Make sure you don't have an external mouse connected to the expansion slice.
- If you just disconnected an external mouse, try exiting and restarting Windows to make the OmniBook touch pad active again.
- From the Start menu, suspend the OmniBook, then turn it on again without moving the pointer.
- Reset the OmniBook.

If a PS/2 keyboard and mouse with Y-adapter don't work

- This configuration is not supported.

If you have problems with the touch pad response

- Check the settings in Control Panel, Mouse.

If the keys do not type the characters marked on them (wrong keyboard layout selected)

- To change the setting in Windows 95, select Control Panel, Keyboard, Language tab, Properties, Keyboard Layout. Change the selection in the field.
- To effect the change in DOS, you must edit the AUTOEXEC.BAT and CONFIG.SYS files. To select the British keyboard layout, un-comment (remove the REM commands) from the lines that activate the British keyboard. To select the United States 101 keyboard layout, delete the command lines that activate the British keyboard.

Infrared Problems

If you have problems with infrared communications

- Make sure the infrared light path is not blocked.
- Check settings in the Setup utility—from the System Devices menu, check that Serial Port B (the infrared port) is enabled.
- For infrared communications, an infrared driver must be installed and the Setup utility setting must be enabled. For details, refer to the drivers' Readme files located in \OmniBook\drivers\Win95.
- Check that only one application is using the infrared port (Serial Port B).
- If you have a Standard IR and Fast IR machine communicating with each other, make sure that they are set to the highest *common speed* (115200 BPS).
- Remove any PC Cards. An IRQ conflict is possible if PC Cards are plugged in.

If an infrared printer doesn't print

- In Windows Help, use the Print Troubleshooter.

Memory Problems

If a message says you are out of memory

- In Windows Help, use the memory troubleshooter.
- If you are having memory problems running MS-DOS programs, in Windows Help use the MS-DOS troubleshooter.

PC Card (PCMCIA) Problems

If the OmniBook doesn't recognize a PC Card

- Remove and reinsert the PC Card.
- If the card requires an IRQ, check that there is one available. Look in Windows Device Manager.
- If infrared is enabled, try disabling it.
- Check the OmniBook website for information about supported PC Cards.
- Try the card in another computer.

If a PC card stops communicating properly

- It may have been reset if the OmniBook suspended or turned off. Exit and restart the application.

Performance Problems

If the OmniBook gets warm

- It is normal for the computer to get warm.
- DOS games and other programs that have heavy CPU usage can raise the temperature.

If the OmniBook pauses or runs sluggishly

- This may be normal Windows 95 behavior (background processing can affect response time).
- If the hard disk has spun down to conserve power, it can take several seconds to spin up. Run PowerPanel (or use the Setup utility if PowerPanel is not running) and increase the hard disk time-out.
- Certain background operations (such as virus scans) can affect performance while they're running.
- Some file browsers may be unresponsive while they're processing a graphic image or waiting for broken network connections to time out.
- Check the amount of available free disk space.

Power and Battery Problems

If the OmniBook turns off immediately after it turns on

- The battery power is probably extremely low. Plug in the ac adapter, or connect a charged battery slice.

If the OmniBook has a short operating time

- Try conserving power using any of the suggestions listed under “To save battery power” on page 3-11.
- Turn down the display brightness.
- Check the Power Management settings in the Setup utility. Make sure they are set to Maximum Power Savings.

If the computer’s battery doesn’t charge

- Make sure the ac adapter is plugged into the power source.
- Check that the ac adapter cables are fully plugged in.
- Move the OmniBook away from any nearby heat source. Unplug the ac adapter and allow the battery to cool down. An elevated battery temperature prevents charging.
- If available, try another ac adapter.
- Refer to the *Support and Service* booklet for service or a replacement battery.

If the battery slice doesn’t charge

- If the battery slice is connected to the OmniBook or to the multimedia expansion slice, the ac power must be connected to the OmniBook, *not the battery slice*.
- If connected to the OmniBook, the battery slice charges *after* the computer’s battery is fully charged.
- Connect ac power to the battery slice *only if the battery slice is not connected to the computer or the multimedia expansion slice*.

If the OmniBook stops responding

- Press the power button, wait a few minutes, then press the power button again to turn the OmniBook back on.
- If nothing happens, insert a paper clip into the system-off as shown. Press the power button again to turn the OmniBook back on.

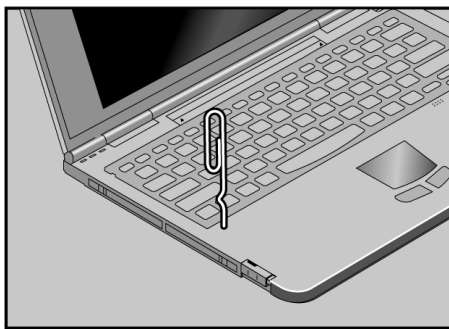

If the OmniBook doesn't suspend automatically

- If you have a connection to another computer, the OmniBook doesn't suspend if the connection is actively in use.
- Check the time-out settings in the Setup utility. Make sure the Suspend time-out is enabled.

If the OmniBook doesn't suspend immediately

- If the OmniBook is performing an operation, it normally waits for the operation to finish.

Printing Problems

If a serial or parallel printer doesn't print

- In Windows Help, use the Print Troubleshooter.
- Check that you are using a proper cable or cable adapter, and that the printer is on.
- Check for paper in the printer or other printer errors.
- Make sure the printer cable is secure at both ends.

If an infrared printer doesn't print

- Make sure the infrared light path is not blocked.
- Check for paper in the printer or other printer errors.
- Make sure Windows is running—infrared printing is supported only while Windows is running.
- An infrared driver must be installed and the Setup utility setting must be enabled. For details, refer to the drivers' Readme files (located in \Omnibook\Drivers).
- In Windows Help, use the Print Troubleshooter.

If the left edge of printed output is missing

- If the printer you are using is a 600-dpi (dots per inch) printer, try selecting a compatible printer driver for a 300-dpi printer. For example, for a 600-dpi HP LaserJet printer, try using the HP LaserJet IIIsi driver (300-dpi). Certain applications may not work properly with 600-dpi printers.

Serial and Parallel Port Problems

If a serial modem doesn't work properly

- In Windows Help use the modem troubleshooter.
- Check the port cable connection (it may be loose).

If the serial or parallel port is not working

- Check settings in the Setup utility (under System Devices). Make sure that Parallel and Serial ports are enabled.
- Check the port cable connection (it may be loose).

Startup Problems

If the OmniBook doesn't respond at turn-on

- Connect the ac adapter.
- Press the power button to try turning on the unit.
- Reset the OmniBook (see page 2-9).

If you get no response, then plug in the ac adapter and try resetting the OmniBook. If you still get no response, the unit requires service.

If the OmniBook doesn't boot from battery power

- Connect the ac adapter, then check battery status (Start, Settings, Control Panel, Power or double-click on the power icon in the taskbar). If the battery is low, leave ac connected to recharge it.
- If you are using a battery slice, then the battery status should show two batteries present (the first for the internal battery, the second for the slice). If the second one is shown Not Present, make sure the slice is properly connected.
- If the battery status shows the first (or only) battery Not Present, then the battery is probably defective and should be replaced.

If the OmniBook doesn't boot from the floppy disk drive

- Check if the floppy disk drive is enabled.

From the Start menu, shut down, then restart the OmniBook.

When you see the HP logo, press F2 to enter the BIOS Setup utility.

From the Main menu, check that Legacy Diskette A: is set to 1.44/1.25 MB.

- Check the boot order in the Setup utility.

From the Main menu, Boot Options, check that the boot sequence is A: then C:.

- Make sure that the floppy disk is bootable. (Try using it to boot from another system.)

Testing the Operation

The OmniBook hardware diagnostic program provides two levels of testing:

- Automated testing using the basic hardware test.
- Advanced testing using the individual hardware tests.

The tests are designed to run after the system reboots. This ensures that the computer will be in a predictable state, so the diagnostic program can properly test the hardware components. The tests are non-destructive and are intended to preserve the state of the computer. The OmniBook reboots when you exit the program so drivers can be loaded.

To create a diagnostic floppy disk

After inserting a formatted floppy disk in the floppy drive, do one of the following to create a diagnostic floppy disk:

- On an OmniBook with a factory software installation, run diaginist from the \Dmi\Hpdiags directory on the hard disk.
- On any computer with a CD-ROM drive, run diaginist from the \Omnibook\Dmi\Hpdiags directory on the OmniBook Recovery CD.
- On any computer with World Wide Web access, download the diagnostic software package from the OmniBook website (<http://www.hp.com/omnibook>), run this file to unpack the files, then run diaginist to create the diagnostic disk.

To run the diagnostic test

1. Insert the diagnostic disk in the floppy drive.
2. Reboot the OmniBook.
3. Go through the first several screens.
4. When the hardware detection finishes, check the list of detected hardware. The following information and devices should be listed if applicable:

Product name	Cache memory	Floppy drives
Serial number	Main memory	IDE drives
BIOS version	Graphics adapter	SoundBlaster audio device
Processor type	Display name	

Note

If any such device is present but not detected, or if its test fails, it may be configured incorrectly in the BIOS Setup utility. You can confirm the problem by running BIOS Setup and checking the settings.

5. Optional: When the hardware detection finishes, press F4 to save system information in the Support Ticket log file, HPSUPPT.TXT.
6. Run the basic test. When prompted, press F2 to start the basic hardware test.
7. Optional: When the test finishes, press F4 to save system and test information in the Support Ticket log file, HPSUPPT.TXT.
8. Optional: Run the advanced tests. When prompted, press F2 to open the advanced test screen.

9. Select and run the appropriate tests. Tests are dimmed if no such hardware is detected. Press the following keys to run tests:

ENTER	Runs the highlighted test.
F5 or SPACE	Marks or unmarks the highlighted test.
F6	Marks or unmarks all tests in the current menu.
F7	Marks or unmarks all tests in all menus.

Batch menu, Run Batch Test, ENTER runs all marked tests. If any test fails, the error is logged (error code and description) and displayed temporarily (error code).

10. Exit. When you are finished running tests, remove the diagnostic disk or Recovery CD, then press ESC to exit and reboot.
11. Optional: Check the log. On any computer, open the HPSUPPT.TXT log file on the floppy disk using Notepad or other text editor. It contains a list of all test results and errors.

Hint

- To test the serial and parallel ports, make sure they are enabled (on) in the Setup utility, Advanced menu.
 - To test Suspend/Resume, make sure that the Switch Button is set to Sus/Res, and Resume On Time is set to On in the Setup utility, Power Saving menu.
 - To test IR, make sure that the infrared port (Serial Port B) is enabled and its Mode is set to FIR in the Setup utility, Advanced menu, I/O Device Configuration.
-

**Specifications and Regulatory
Information**

Specifications and Regulatory Information

Your OmniBook is designed to provide trouble-free operation. The following suggestions can help you maintain its dependability:

- Observe the temperature limits and other specifications listed in the next section.
- If you have problems, see the problem-solving suggestions in Troubleshooting.
- If you think your OmniBook might need repair service, see the warranty and service information in the *Support and Service* booklet.

To contact Hewlett-Packard

If you have questions that this manual does not answer (even after looking in the contents and index), you can contact Hewlett-Packard at the address or phone number listed in the *Support and Service* booklet or in OmniBook Support in the online OmniBook Library. Please have your OmniBook with you.

To clean the OmniBook

You can clean the OmniBook with a soft cloth dampened either in clean water or in water containing a mild detergent. Do not use an excessively wet cloth nor allow water inside the case. Do not use any abrasive cleaners, especially on the display. *Do not apply any cleaner directly to the display or keyboard.* Instead, apply the cleaner to a soft cloth and then gently wipe the display and keyboard. You can clean the keyboard with a vacuum cleaner to remove accumulated dust.

Hardware Specifications

Windows provides information on your computer's hardware specifications. For instance,

- The Control Panel gives you information on various components, such as Display (for pixels and colors) and System (for processor and RAM).
- The Explorer Properties (right-click the selected drive) tells you about the capacity and available space of that drive.

The computer also displays configuration information when you reset the computer and press F2.

Software System Resources

Below are the default values for the system resources. To see other, non-default possibilities, refer to the Setup utility, which lists port and audio device configurations in the Input/Output menu. The tables in this section show typical resource usage as set up by the OmniBook BIOS. Plug-and-play operating systems, drivers, and Setup utility settings may change some of the entries.

System Interrupts	OmniBook only	OmniBook with Expansion Slice
0	System timer	System timer
1	Keyboard	Keyboard
2	Cascade to IRQ 9	Cascade to IRQ 9
3	COM2 infrared port	COM2 infrared port
4	Free	COM1
5	ESS1879	ESS1879
6	Floppy drive controller	Floppy drive controller
7	Free	LPT1
8	Real-time clock	Real-time clock
9	CardBus controller	CardBus controller
10	Free	Free
11	Free	Free
12	Touch pad	Touch pad
13	Numeric data processor	Numeric data processor
14	Internal hard disk (primary IDE controller)	Internal hard disk (primary IDE controller)
15	Internal CD-ROM drive (secondary IDE controller)	Internal CD-ROM drive (secondary IDE controller)

System Memory Addresses	OmniBook only	OmniBook with Expansion Slice
00000 - 9FFFF	System memory	System memory
A0000 - BFFFF	Video	Video
C0000 - CBFFF	Video BIOS	Video BIOS
CC000 - DFFFF	Free (see below)	Free (see below)
E0000 - FFFFF	System BIOS	System BIOS

Valid uses for memory addresses CC000-DFFFF:

- Upper memory blocks (UMBs).
- PC Card memory windows.

System Input/Output Addresses (100-3FF)

	OmniBook only	OmniBook with Expansion Slice
170-177	Secondary HDD controller	Secondary HDD controller (CD-ROM)
1F0-1F7	Internal hard disk	Internal hard disk
20-20	Joystick	Joystick
220-22F	ESS1879	ESS1879
376	Secondary HDD controller (internal CD-ROM)	Secondary HDD controller (CD-ROM)
378-37F	Free	Free
388-38B	Sound	Sound
3B0-3BB	VGA adapter	VGA adapter
3C0-3DF	VGA adapter	VGA adapter
3E0-3E1	PCMCIA controller	PCMCIA controller
3F0-3F5	Floppy controller	Floppy controller
3F6	Primary HDD controller	Primary HDD controller
3F7	Floppy controller	Floppy controller
3F8-3FF	Free	COM1

DMA Channels

	OmniBook only	OmniBook with Expansion Slice
0	Free	Free
1	ESS1879	ESS1879
2	Floppy drive	Floppy drive
3	ESS1879	ESS1879
4	DMA controller	DMA controller
5	Free	Free
6	Free	Free
7	Free	Free

Safety Information

Power Cords

The power cord supplied with the OmniBook ac adapter should match the plug and voltage requirements for your local area. Regulatory approval for the ac adapter has been obtained using the power cord for the local area. However, if you travel to a different area and need to connect to a different outlet or voltage, you should use one of the power cords listed below. To purchase a power cord (including one for a country not listed below) or a replacement ac adapter (HP part number F1434A), contact your local Hewlett-Packard dealer or Sales and Service office.

Power Cords

Country	Rated Voltage and Current	HP Part Number
Canada Mexico Philippines Taiwan United States	125 Vac (3 A)	8120-6313
East and West Europe Egypt Saudi Arabia	250 Vac (2.5 A)	8120-6314
Hong Kong Singapore United Kingdom	250 Vac (2.5 A)	8120-6315
Australia New Zealand	250 Vac (2.5 A)	8120-6312
Japan	125 Vac (3 A)	8120-6316
India South Africa	250 Vac (2.5 A)	8120-6317
People's Republic of China	250 Vac (2.5 A)	8120-8373

W A R N I N G

Working In Comfort

Improper use of keyboards and other input devices has been associated with ergonomic injury. For information about reducing your risk, see the “Working in Comfort” instructions provided with your OmniBook or at our website, <http://www.hp.com/ergo>.

Battery Safety

- To avoid risk of fire, burns, or damage to your battery slice, do not allow a metal object to touch the battery contacts.
- The battery slice is suitable for use only with compatible OmniBook models. Check the *Support and Service* booklet for your local HP contact.
- Do not disassemble the battery slice. There are no serviceable parts inside.
- Do not dispose of the battery slice in fire or water.
- Handle a damaged or leaking battery slice with extreme care. If you come in contact with the electrolyte, wash the exposed area with soap and water. If it contacts the eye, flush the eye with water for 15 minutes and seek medical attention.
- Do not expose the battery slice to high storage temperatures (above 60 °C, 140 °F).
- When discarding a battery slice, contact your local waste disposal provider regarding local restrictions on the disposal or recycling of batteries.
- To obtain a replacement battery slice, contact your local dealer or HP sales office.
- Do not charge the battery slice if the ambient temperature exceeds 45 °C (113 °F).

Laser Safety

The CD-ROM drive used with the OmniBook is certified as a Class 1 laser device according to the U.S. Department of Health and Human Services (DHHS) Radiation Performance Standard and International Standards IEC 825 / IEC 825-1 (EN60825 / EN60825-1). This device is not considered harmful, but the following precautions are recommended:

- Ensure proper use by reading and following the instructions carefully.
- If the unit requires service, contact an authorized HP service center—see the *OmniBook Support and Service* booklet.
- Do not attempt to make any adjustment of the unit.
- Avoid direct exposure to the laser beam—do not open the unit.

CLASS 1 LASER PRODUCT
LASER KLASSE 1

LED Safety

The infrared port located on the back panel of the OmniBook is classified as a Class 1 LED (light-emitting diode) device according to International Standard IEC 825-1 (EN60825-1). This device is not considered harmful, but the following precautions are recommended:

- If the unit requires service, contact an authorized HP service center—see the *OmniBook Support and Service* booklet.
- Do not attempt to make any adjustment of the unit.
- Avoid direct eye exposure to the infrared LED beam. Be aware that the beam is invisible light and cannot be seen.
- Do not attempt to view the infrared LED beam with any type of optical device.

CLASS 1 LED PRODUCT
LEDSCHÜTZKLASSE 1 PRODUKT

Regulatory Information

This section presents information that shows how the OmniBook Sojourn complies with regulations in certain regions. Any modifications to the OmniBook not expressly approved by Hewlett-Packard could void the authority to operate the OmniBook in these regions.

U.S.A.

The OmniBook Sojourn generates and uses radio frequency energy and may interfere with radio and television reception. The OmniBook complies with the limits for a Class B computing device as specified in Part 15 of FCC Rules, which provide reasonable protection against such interference in a residential installation. In the unlikely event that there is interference to radio or television reception (which can be determined by removing the ac adapter and shutting down the OmniBook), try the following:

- Reorienting or relocating the receiving antenna.
- Relocating the OmniBook with respect to the receiver.
- Connecting the OmniBook ac adapter to another power outlet.

Connections to Peripheral Devices

To maintain compliance with FCC Rules and Regulations, use properly shielded cables with this device.

For more information, consult your dealer, an experienced radio/television technician, or the following booklet, prepared by the Federal Communications Commission: *How to Identify and Resolve Radio-TV Interference Problems*. This booklet is available from the U.S. Government Printing Office, Washington, DC 20402, Stock Number 004-000-00345-4. At the first printing of this manual, the telephone number was (202) 512-1800.

Specifications and Regulatory Information
Regulatory Information

U.S. Declaration of Conformity

Responsible Party: Hewlett-Packard Company
Manager of Corporate Product Regulations
3000 Hanover Street
Palo Alto, CA 94304

(415) 857-1501

declares that the product(s)

Trade name: Hewlett-Packard Company

Product name: HP OmniBook Sojourn

Complies with Part 15 of the FCC Rules. Operation is subject to the following two conditions:

1. This device may not cause harmful interference, and
2. This device must accept any interference received, including interference that may cause undesired operation.

Canada

This digital apparatus does not exceed the Class B limits for radio noise emissions from digital apparatus as set out in the radio interference regulations of the Canadian Department of Communications.

Le présent appareil numérique n'émet pas de bruits radioélectriques dépassant les limites applicables aux appareils numériques de Classe B prescrites dans le règlement sur le brouillage radioélectrique édicté par le Ministère des Communications du Canada.

Japan

この装置は、情報処理装置等電波障害自主規制協議会（VCCI）の基準に基づくクラスB情報技術装置です。この装置は、家庭環境で使用することを目的としていますが、この装置がラジオやテレビジョン受信機に近接して使用されると受信障害を引き起こすことがあります。

取り扱い説明書に従って正しい取り扱いをして下さい。

European Declaration of Conformity

Products sold in Europe by Hewlett-Packard and its authorized dealers meet the specifications listed below.

Declaration of Conformity (according to ISO/IEC Guide 22 and EN 45014)

Manufacturer: Hewlett-Packard Company
Address: Hewlett-Packard Company
Mobile Computing Division
19310 Pruneridge Ave.
Cupertino, CA 95014
declares that the following product
Product name: HP OmniBook Sojourn, all models
Options: All
Safety: conforms to the following product specifications
IEC 950:1991+A1,A2 / EN 60950 (1992)+A1,A2
IEC 825-1:1993/EN60825-1:1994, Class 1
EMC: EN 50082-1:1992
CISPR 22:1993 / EN 55022 (1994): Class B [1]
IEC 801-2:1991 / prEN 55024-2 (1992): 4kV CD, 8kV AD
IEC 801-3:1984 / prEN 55024-3 (1991): 3V/m
IEC 801-4:1988 / prEN 55024-4 (1992): 0.5 kV signal lines, 1.0kV
power lines
Supplementary Information: The product herewith complies with the requirements of the Low
Voltage Directive 73/23/EEC and the EMC Directive 89/336/EEC and
carries the CD mark accordingly.

The HP F1434A ac adapter used with this product is designed to
operate on all power systems, other than IT power systems.
[1] The product was tested in a typical configuration with
Hewlett-Packard personal computer peripherals.

Quality Department
Hewlett-Packard Company
Mobile Computing Division

Index

102 key, 2-15

A

ac adapter, 1-9

status panel icon, 3-4

ac power, 1-9

AC profile, 1-17

address

audio jacks, 4-21

Hewlett-Packard, 7-2

HP website, 1-7

adjusting display, 2-12

Advanced Power Management (APM), 3-2

atomic icon, 1-16

audio devices

built-in microphone, 1-6

connecting, 4-21

drivers, 5-3, 5-4

external microphone, 4-21

muting, 4-21

speakers, 1-6, 4-21

troubleshooting, 6-4

Auto Suspend, 1-14

automatic time-outs, 3-12

B

backing up, 2-2

backslash key (British), 2-15

battery

charging times, 3-7

low warning, 3-4

safeguards, 3-2

troubleshooting, 6-10

battery (external slice)

connecting, 3-5

connector door, 3-5

removing, 3-6

with expansion slice, 4-4

battery (internal)

operating time, 3-11

recharging, 3-4

saving power, 3-11

status, 3-4

typical life, 3-3

battery power

conserving, 3-10

preserving, 3-11

with PC Card, 3-11

battery slice

charging, 3-7

charging times, 3-8

BIOS

resources, 7-4

Setup utility, 1-11

updating, 5-8

boot password, 1-13

British keyboard layout

- 102 key, 2-15
- backslash, 2-15

C

cable (Kensington), 2-18

cards. *See* PC Cards

CD-ROM drive

- inserting CD, 4-8
- opening manually, 4-9
- removing CD, 4-8
- safety, 4-9

certificate of authenticity, 1-10

channels (DMA), 7-5

charge order (battery), 3-8

charging

- ac, 1-9
- battery slice, 3-7
- first time, 1-9
- internal battery, 3-4
- time, 3-8
- times, 3-4

charging time

- internal battery, 3-7

CHKDSK, 6-5

cleaning the OmniBook, 7-2

clicking items, 2-10

compatible PC Cards, 4-21

configuring

- audio devices, 7-4
- lid switch, 2-8
- OmniBook, 1-11
- power button, 2-7
- Suspend mode, 2-7
- system resources, 7-4
- touch pad, 2-11

connecting

- audio devices, 4-21
- battery (external slice), 3-5
- infrared, 4-23
- keyboard, 4-15

monitor, 4-11

multimedia expansion slice, 4-4

parallel device, 4-13

PC Card, 4-19

serial device, 4-14

USB device, 4-17

Corporate Evaluator's Guide, 5-5

corrupted files, 6-5

D

daisy-chain connection, 4-17

data

- backing up, 2-2

default values, 7-4

devices

- audio, 4-21
- conflicts, 1-12
- connecting, 4-10
- drivers, 5-3, 5-4
- parallel, 4-13
- serial, 4-14
- USB, 4-17

discharge order (battery), 3-8

display

- adjusting, 2-12
- options, 4-12
- resolution, 2-12
- troubleshooting, 6-4
- white-out, 2-4

DMA channels, 7-5

docking system. *See* multimedia expansion slice

dot matrix printer, 4-13

dragging items, 2-10

drivers

- installing, 5-5
- on Recovery CD, 5-5

drives

- CD-ROM drive, 4-8
- floppy disk drive, 4-7
- hard disk, 2-16

E

- ECP, 4-13
- embedded keypad, 2-13
- enabling
 - display device, 4-12
- enhanced battery slice, 3-8
- EPP, 4-13
- ergonomics, 7-7
- exchange
 - computer, 2-2
 - repair, 6-2
- expansion slice, 2-18
- external
 - audio devices, 4-21
 - connections, 4-10
 - display, 4-11
 - infrared device, 4-23
 - keyboard, 4-15
 - parallel device, 4-13
 - serial device, 4-14
 - USB device, 4-17

F

- FAT32, 5-4
- floppy disk drive, 4-7
- Fn + DOWN Arrow (down), 2-13
- Fn + F10 (mute), 2-13
- Fn + LEFT Arrow, 2-13
- Fn + NL/SI (scroll lock), 2-13
- Fn + RIGHT Arrow, 2-13
- Fn + UP Arrow (up), 2-13
- Fn key
 - + F5 (display options), 4-12
- Fn key+ F8 (increase brightness), 2-12
- Fn key+ F9 (decrease brightness), 2-12
- Fn keys, 2-13

H

- hard disk drive, 2-16, 6-5
 - time-out, 1-14

hard-drive

- time-out, 3-12
- hot keys, 2-13
- Idle mode, 1-14
- infrared
 - connections, 4-23
 - light path, 6-7
 - printing, 6-7
 - troubleshooting, 6-7
- infrared port, 4-23, 6-7
- InkJet printer, 4-13
- inserting CD, 4-8
- installing
 - HP software, 5-4
 - operating systems, 5-4
 - PC Cards, 4-19
 - Windows 95 4.0 950 B, 5-7
 - Windows for Workgroups, 5-4, 5-5
- internal battery
 - typical life, 3-3
- interrupts (system), 7-4

K

- Kensington lock, 2-18
- keyboard
 - external PS/2, 4-15
 - Fn keys, 2-13
 - internal, 2-13
 - status lights, 2-16
 - troubleshooting, 6-6
 - Windows 95 keys, 2-14
- keyboard layout
 - British, 1-10
 - correcting, 6-6
 - selecting, 1-10
 - U.S., 1-10

L

- laser printer, 4-13
- laser safety, 4-9, 7-8
- LED safety, 7-8

license agreement, iii

lid switch

 configuring, 2-8

lights

 drive activity, 2-16

 keyboard, 2-16

 power, 2-16

low battery

 condition, 3-2

 warning, 3-4

M

Maximum Battery Life profile, 1-17

Maximum Performance profile, 1-17

microphone, 4-21

MicroSaver lock, 2-18

modes, 1-14

monitor. *See* display

mouse

 troubleshooting, 6-6

multimedia expansion slice, 4-3, 4-4

 pop-out speakers, 4-21

 removing, 4-5

 security, 2-18

 troubleshooting, 6-3

 USB ports, 4-17

O

off button, 2-4

off mode, 2-5, 2-6

OmniBook

 cleaning, 7-2

 configuring, 1-11

 turning on and off, 2-4

on button, 2-4

operating systems

 Windows 95

 recovering 4.0 950 B, 5-7

P

parallel device

 connecting, 4-13

password

 for drive A, 1-13

 on boot, 1-13

 setting, 2-17

 supervisor, 1-13, 2-17

 user, 1-13, 2-17

passwords

 changing, 2-18

 deleting, 2-18

 forgetting, 2-17

 recovery, 2-17

 setting, 2-17

 Windows, 1-10

PC Cards

 compatible, 4-21

 inserting, 4-19

 removing, 4-20

 saving power, 3-11

 troubleshooting, 6-8

 types, 4-19

Phoenix PowerPanel, 1-17

plug requirements, 7-6

pointing device. *See* touch pad

port replicator. *See* multimedia expansion slice

power

 Advanced Power Management, 3-2

 connecting to ac, 1-9

 conserving, 3-12

 managing, 3-2

 saving, 3-11

Power button, 2-4

 configuring, 2-7

 holding too long, 2-4

 suspending OmniBook, 2-6

power cords, 7-6

power management

PowerPanel, 1-16

PowerPanel, 1-16

Help, 1-17

profiles, 3-12

setting time-outs, 3-12

printing

compatible printers, 4-13

parallel connection, 4-13

troubleshooting, 6-12

product ID, 1-10

product specifications, 7-2

profiles

PowerPanel, 1-17

power-use, 3-12

protection

security cable, 2-18

R

recharging

internal battery, 3-4

time, 3-8

times, 3-4

recovering Windows, 5-4

Recovery CD

contents, 5-4

drivers, 5-5

regulatory information, 7-9

reinstalling

Windows 95 4.0 950 B, 5-7

removing

battery (external slice), 3-6

floppy disk, 4-7

multimedia expansion slice, 4-5

PC Cards, 4-20

removing CD, 4-8

repair, 6-2

exchange, 2-2

resetting

OmniBook, 2-8

S

safety

CD-ROM, 4-9

ergonomics, 7-7

laser, 4-9, 7-8

LED, 7-8

power, 7-6

voltage, 7-6

save to disk mode, 2-5, 2-6

saving battery power, 3-11

security cable, 2-18

selecting

items, 2-10

text, 2-10

serial device

connecting, 4-14

conserving power, 3-11

USB, 4-17

Serial Port B. *See* infrared port

service

booklet, 1-4

HP service center, 7-8

setting

passwords, 2-17

time-outs, 1-14

setting up

OmniBook configuration, 1-11

slice. *See* battery slice

software

license, iii

resources, 7-4

speakers (pop-out), 4-21

specifications, 7-2

display, 2-12

hardware, 7-3

power cord, 7-6

regulatory, 7-9

safety, 7-6, 7-7

software system, 7-4

- Standby
 - setting time-out for, 1-14
 - time-out, 3-12
- standby mode, 2-5, 2-6
- starting activity, 2-4
- stopping activity, 2-4
- supervisor password, 2-17
- support, 7-8
- Support and Service booklet, 1-7
- Support Utility Disk, 5-4
- Suspend
 - by closing lid, 2-6
 - mode, 1-14
 - password on resume, 1-13
 - time-out, 3-12
 - with power button, 2-6
- suspend mode, 2-5, 2-6
 - configuring, 2-7
- suspending activity, 2-4
- switch (lid), 2-8
- system resources
 - DMA channels, 7-5
 - system interrupts, 7-4
- System-off button, 2-8

T

- time-outs
 - Auto Suspend, 1-14
 - hard disk, 1-14
 - setting, 3-12
 - video, 1-14
- toolbar
 - PowerPanel, 1-16
- touch pad
 - configuring, 2-11
 - controlling pointer, 2-10
 - dragging objects, 2-10
 - enhancements, 2-11
 - introduction, 2-10
 - performance, 2-11
 - settings, 2-11
 - troubleshooting, 6-6
 - tutorial, 2-11
- troubleshooting
 - audio devices, 6-4
 - CD-ROM drive, 6-3
 - display, 6-4
 - hard disk drive, 6-5
 - infrared, 6-7
 - keyboard or mouse, 6-6
 - PC Cards, 6-8
 - power, 6-10
 - printing, 6-12
 - startup, 6-14
 - touch pad, 6-6
- turning off OmniBook
 - methods, 2-6
 - reset, 2-8
- turning OmniBook on and off, 2-4
- typical battery life, 3-3

U

- Universal Serial Bus (USB)
 - connecting, 4-17
 - daisy-chain connection, 4-17
- user password, 2-17

V

- vertical bar key
 - British, 2-15
- video
 - time-out, 3-12
- video time-out, 1-14
- virus scan, 6-5
- voltage requirements, 7-6

W

- warning (low battery), 3-4
- website, 1-7
- white out
 - display, 2-4

Windows 95
documentation, 1-7
keys, 2-14
license agreement, 1-10, 4-6
version 4.0 950 B, 5-7
Windows 95 keys, 2-13
Windows setup

keyboard, 1-10
product ID, 1-10
Working in Comfort, 7-7

Z
zoomed video, 2-12, 4-19

Other ManualsLib Projects



www.manualslib.com



www.manualslib.de



www.manualslib.es



www.manualslib.fr



www.manualslib.nl



www.manualslib.mx



www.manualslib.tech 30+ Languages